

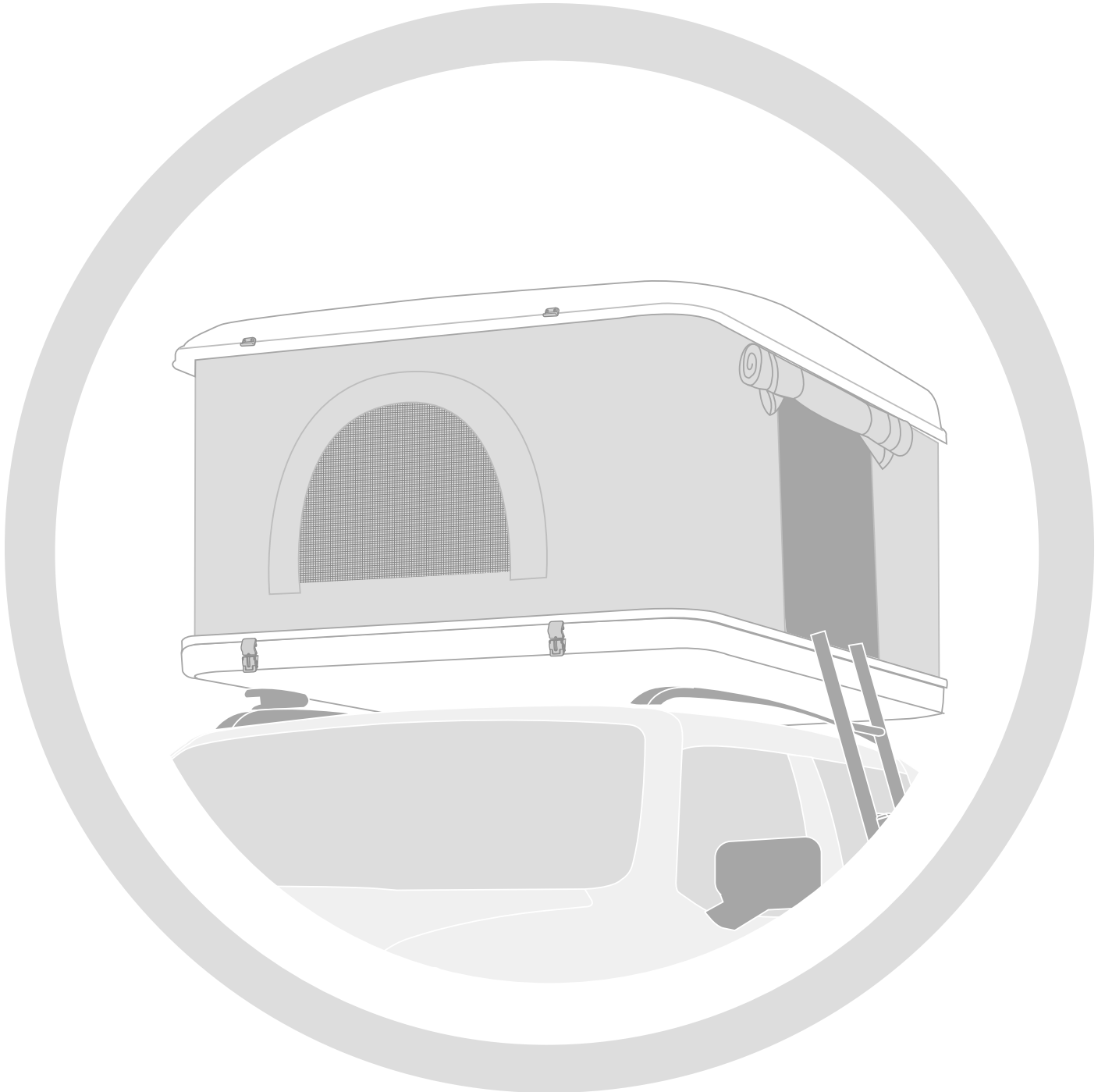





# AIRTOP SERIES INSTRUCTIONS



# WARNINGS

Avvertenze • Avertissement • Warnungen



MODELS <i>Modelle Modèles Modelli</i>	TENT WEIGHT <i>Zeltgewicht Poids de la tente Peso della tenda</i>	MAXIMUM OCCUPANTS WEIGHT <i>Maximales Bewohnergewicht Poids Maximum des occupants Peso massimo degli occupanti</i>	MEASURES WHEN CLOSE <i>Abmessungen bei geschlossenem Zelt Dimensions (tente fermée) Misure chiuse</i>	MEASURES WHEN OPEN <i>Abmessungen bei offenem Zelt Dimensions (tente ouverte) Misure aperte</i>	INTERNAL VOLUME* <i>Innenvolumen Capacité interne de la tente Capacità interna</i>
<i>AirTop Small</i>	<i>ca. 60 kg</i>	 <i>ca. 180 kg</i>	<i>130x210x33 cm</i>	<i>130x110x94 cm</i>	<i>ca. 271 l</i>
<i>AirTop Medium</i>	<i>ca. 65 kg</i>	 <i>ca. 230 kg</i>	<i>145x210x33 cm</i>	<i>145x210x94 cm</i>	<i>ca. 305 l</i>
<i>AirTop Large</i>	<i>ca. 77 kg</i>	 <i>ca. 280 kg</i>	<i>165x210x33 cm</i>	<i>165x210x94 cm</i>	<i>ca. 340 l</i>
<i>AirTop 360° Small</i>	<i>ca. 60 kg</i>	 <i>ca. 180 kg</i>	<i>130x210x33 cm</i>	<i>130x110x94 cm</i>	<i>ca. 271 l</i>
<i>AirTop 360° Medium</i>	<i>ca. 65 kg</i>	 <i>ca. 230 kg</i>	<i>145x210x33 cm</i>	<i>145x210x94 cm</i>	<i>ca. 305 l</i>
<i>AirTop 360° Large</i>	<i>ca. 77 kg</i>	 <i>ca. 280 kg</i>	<i>165x210x33 cm</i>	<i>165x210x94 cm</i>	<i>ca. 340 l</i>

The GRP (fiberglass) outer shells are all handmade and finished, therefore some variations may appear in the finished weights (Manufacturers tolerance rate is within 10%).

Da die Herstellung der Glasfaserschalen manuell erfolgt, können unterschiedliche Zeltgewichte auftreten.

(Da es sich bei Dachzelten um handwerklich gefertigte Produkte handelt, sind Abweichungen bei Gewichten und Abmessungen im Rahmen üblicher Toleranz (10% möglich).

La production des coques en fibre résine est réalisée à la main, raison pour laquelle il est possible de noter des différences de poids au niveau de la tente (la marge de tolérance de fabrication est de l'ordre de 10%).

La produzione dei gusci in vetroresina è realizzata manualmente, di conseguenza è possibile riscontrare delle variazioni del peso della tenda (la tolleranza nell'ambito della costruzione di fabbrica è del 10%).

(\* Approximate value indicating the volumetric capacity of the upper shell of the tent, when the tent is closed

Ungefähres Volumen des Stauraums in der oberen Zeltschale, bei geschlossenem Zustand.

Valeur approximative indiquant la capacité volumétrique de la coque supérieure lorsque la tente est fermée

Valore approssimativo che indica, a tenda chiusa, la capacità volumetrica del guscio superiore.

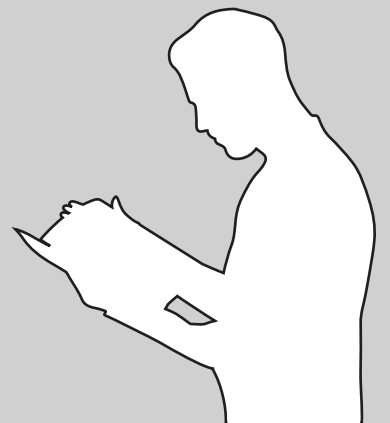
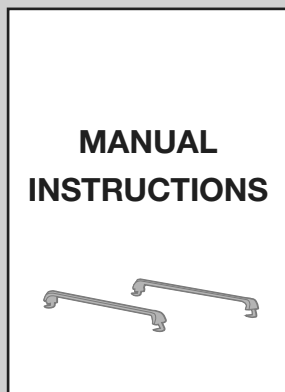
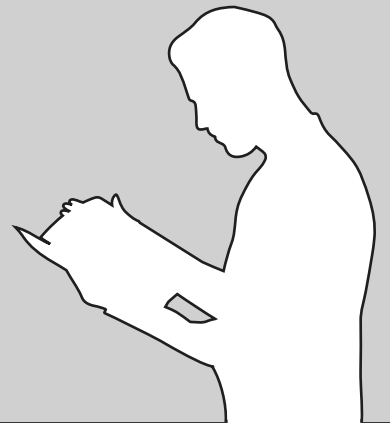
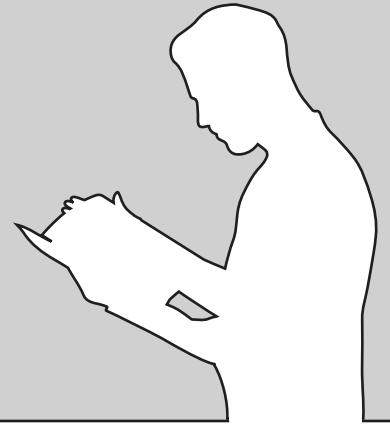
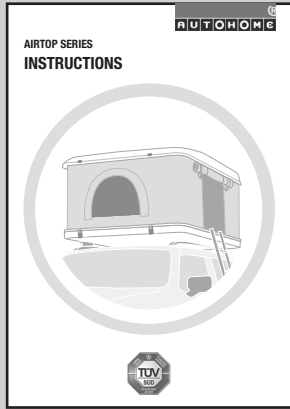

**Kg P1**



**Kg P2**



**(P1 + P2) ≤ Kg P<sub>MAX</sub>**



**Kg P<sub>MAX</sub>**

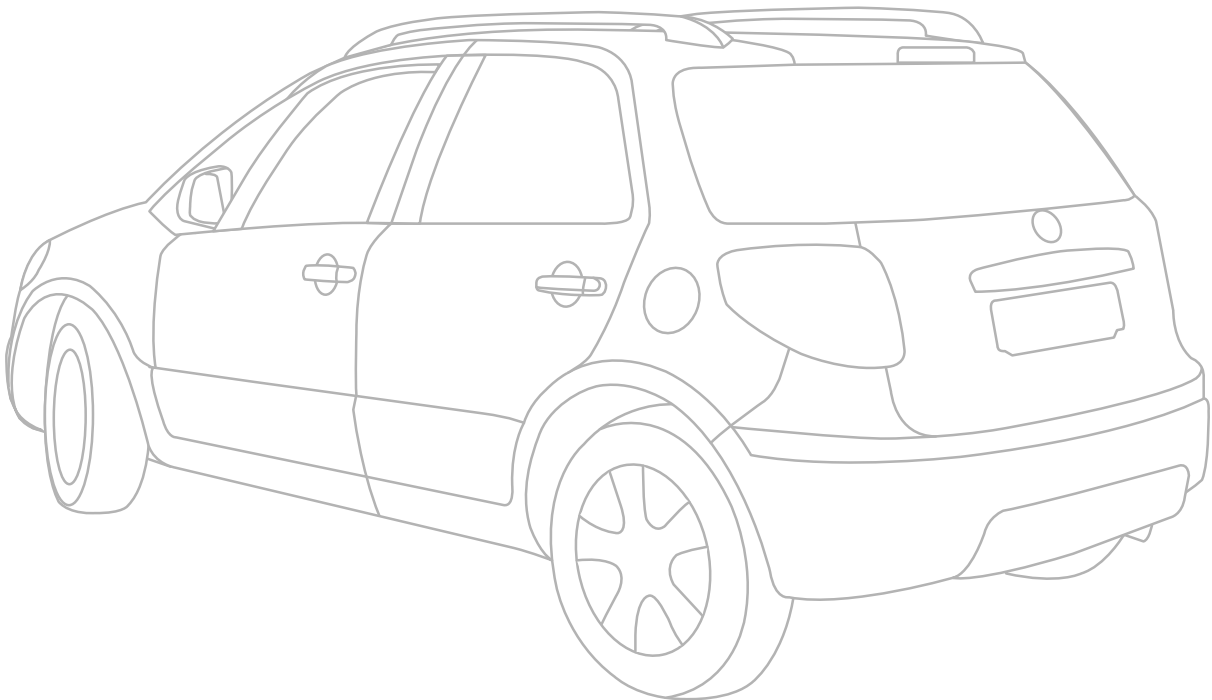

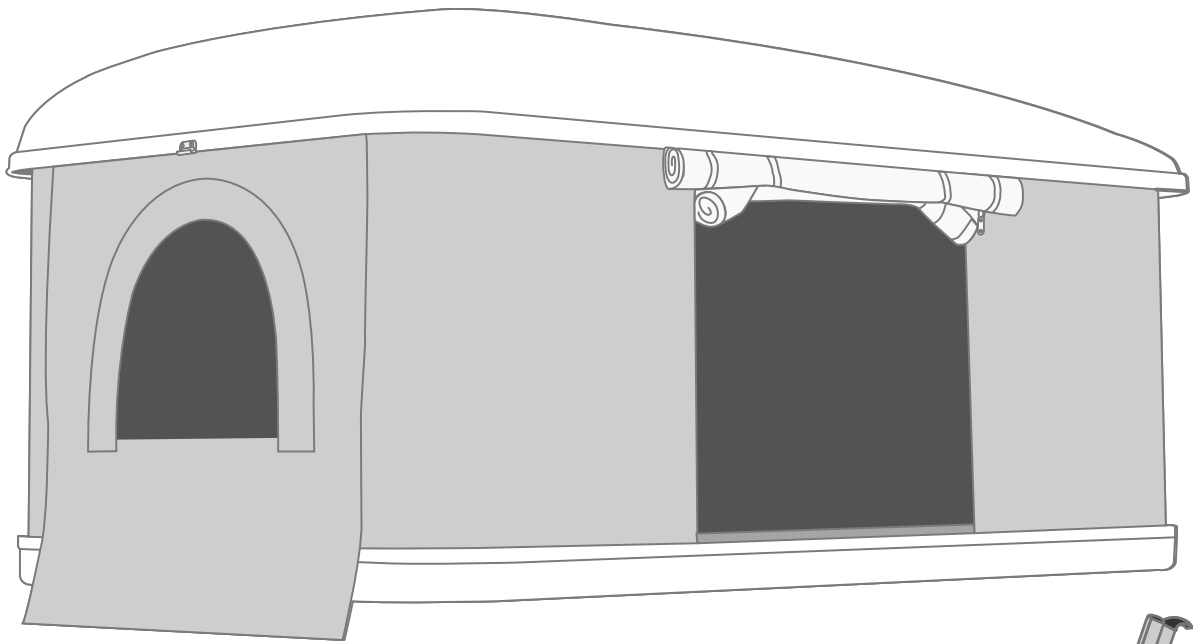

**UP**

**UNDER**

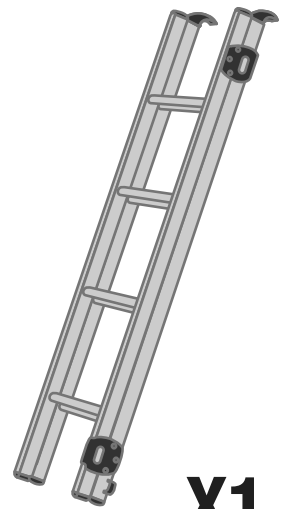

**X8**

**X4**

**X4**

**X8**

**X1**

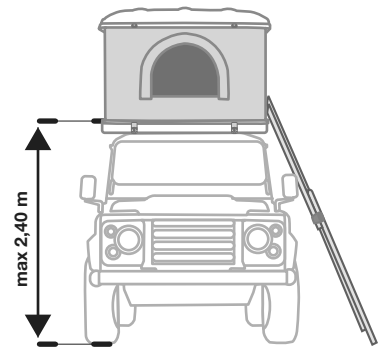
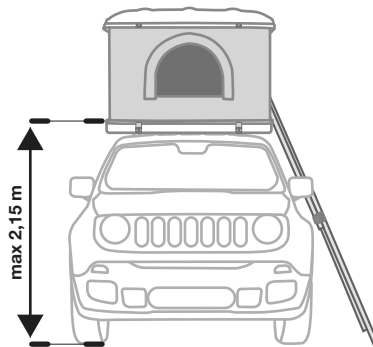
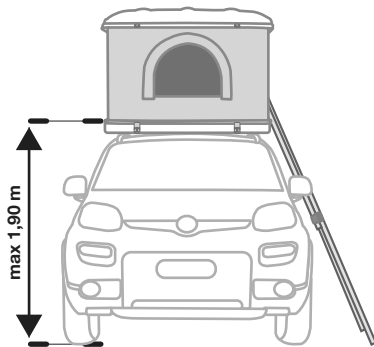

Ladder	H closed	H opened	Width	Thickness
STANDARD	120 cm	200 cm	34 cm	8 cm
4X4	130 cm	222 cm	34 cm	8 cm
EXTRA LONG	147 cm	247 cm	34 cm	8 cm

# POSITIONING

Posizionamento • Placement • Platzierung

1

## Minimum length

Lunghezza minima • Longueur minimale • Mindestlänge

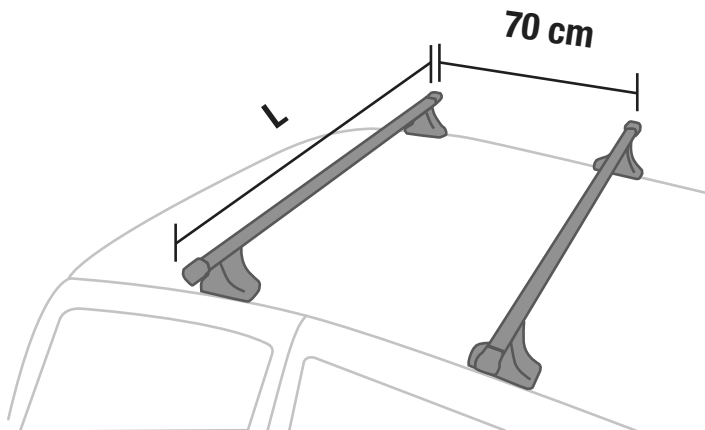

ROOF TENT	L
AirTop <b>Small</b>	124 cm
AirTop <b>Medium</b>	142 cm
AirTop <b>Large</b>	160 cm

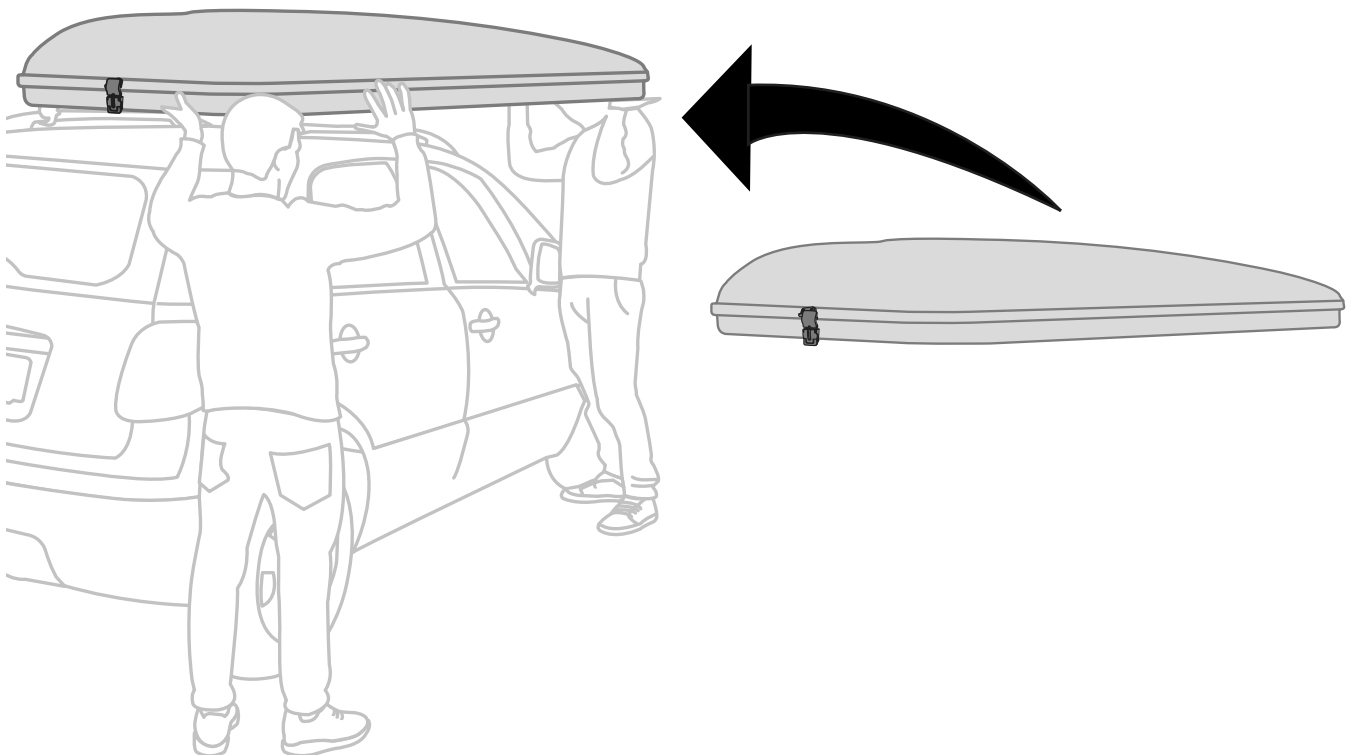

2

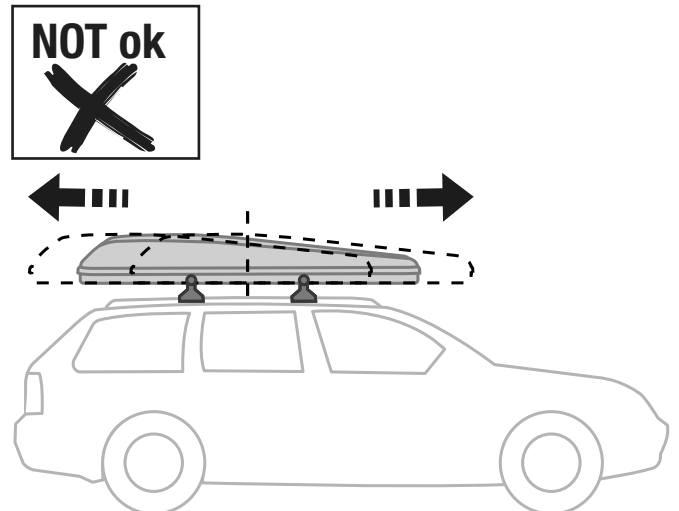
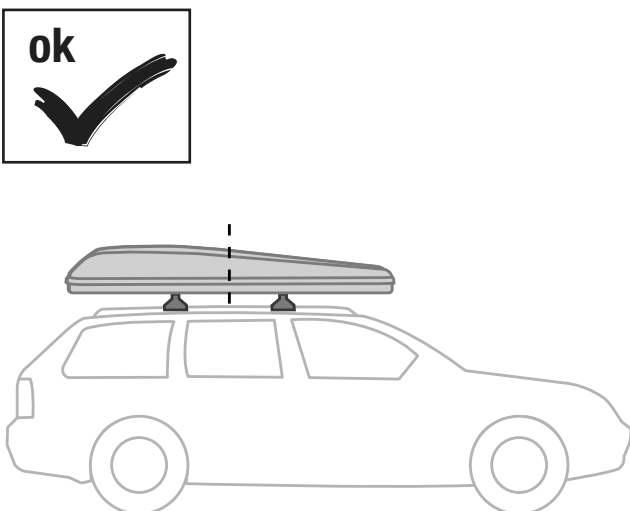
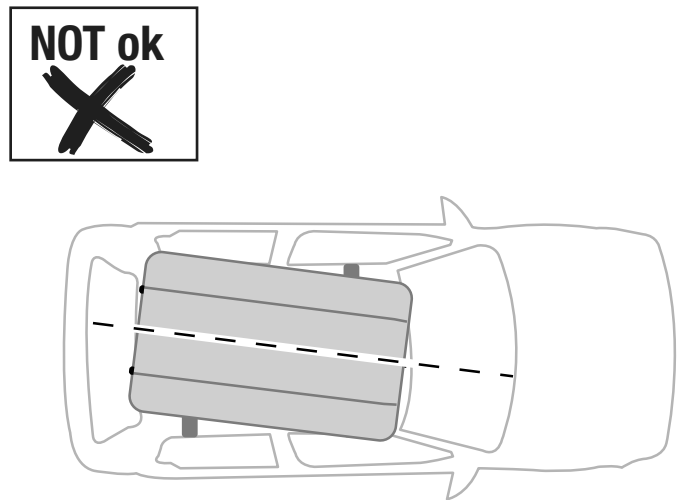
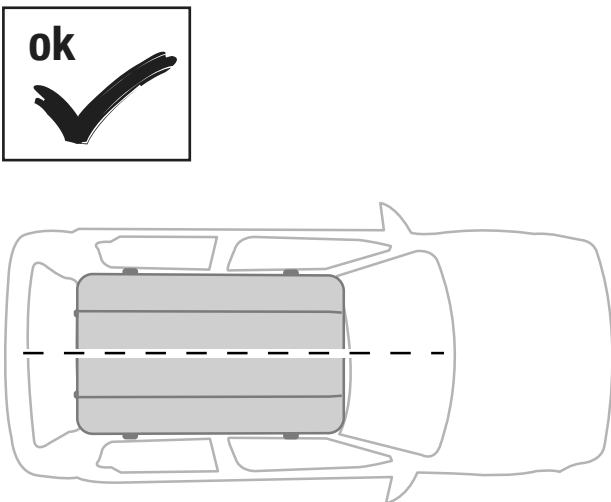
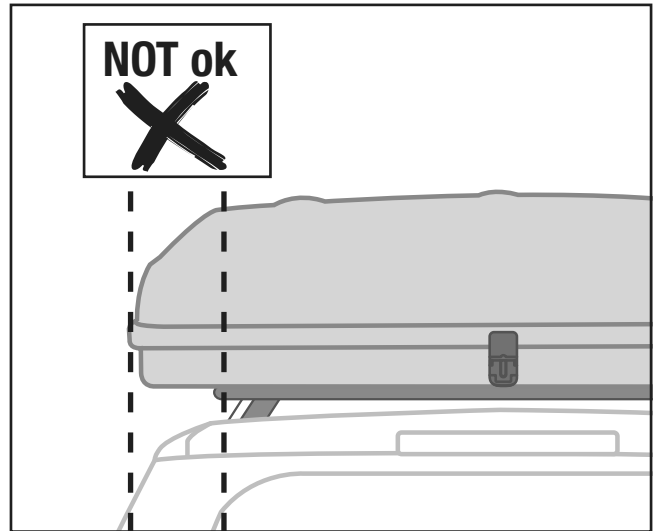
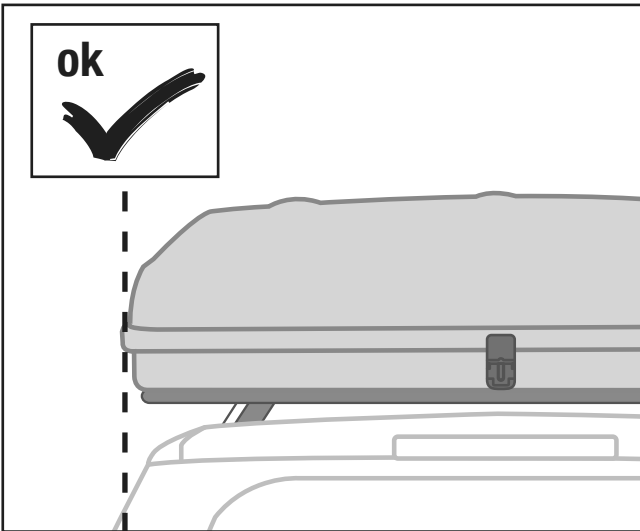

# FIXING

Fissaggio • Fixation • Befestigung

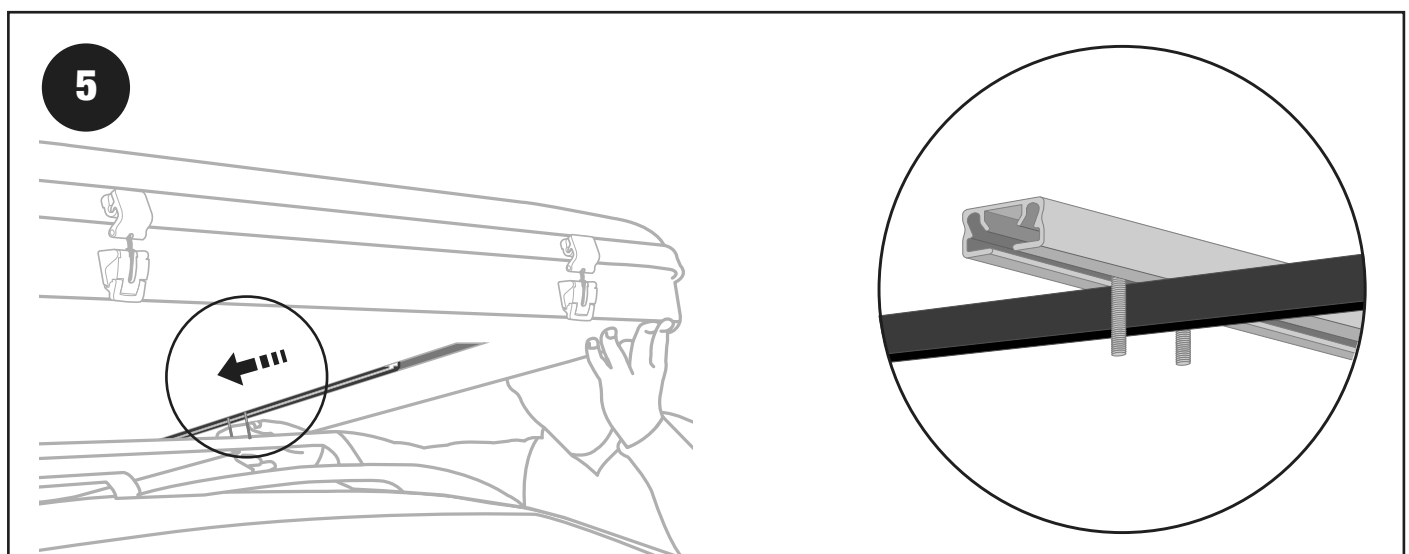
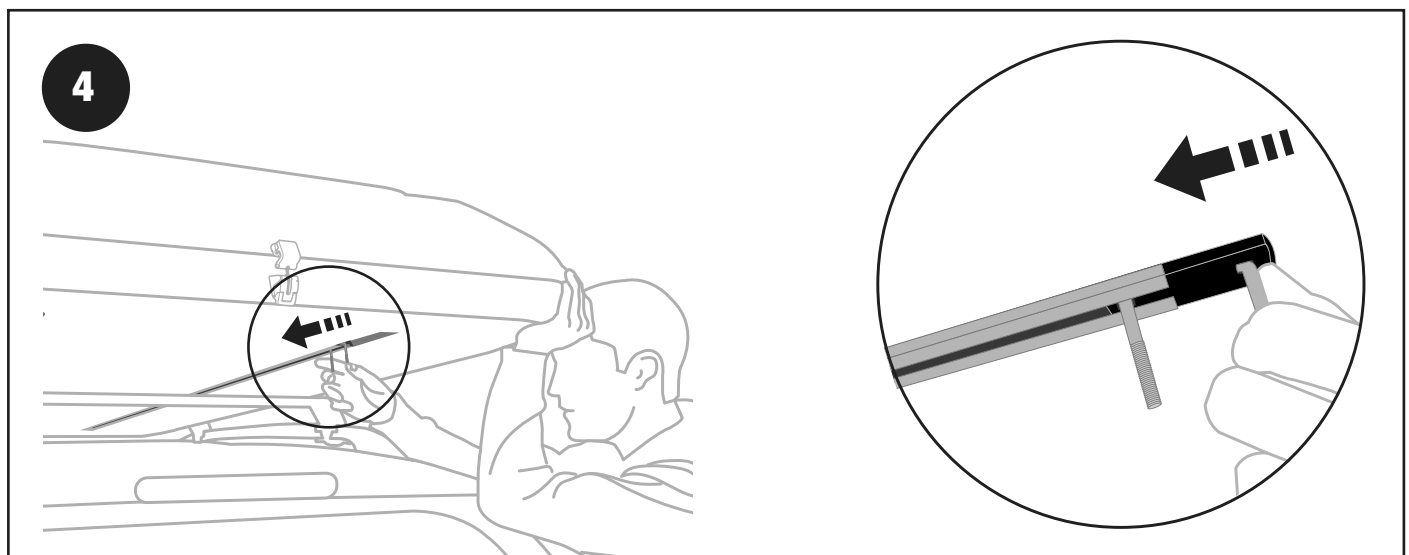
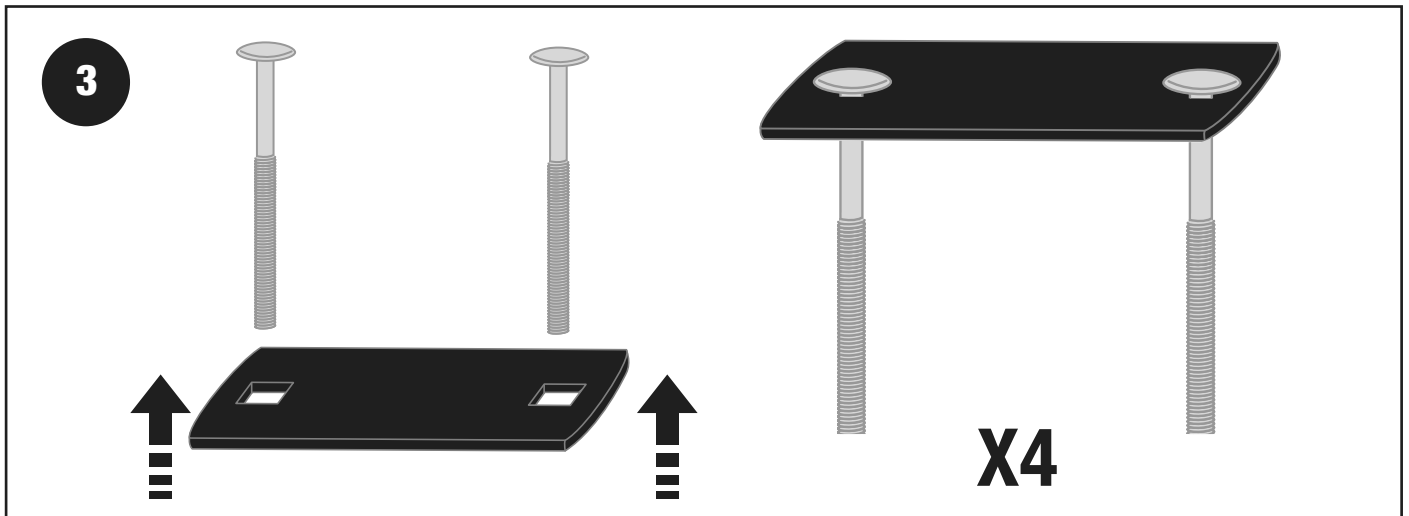



**6**

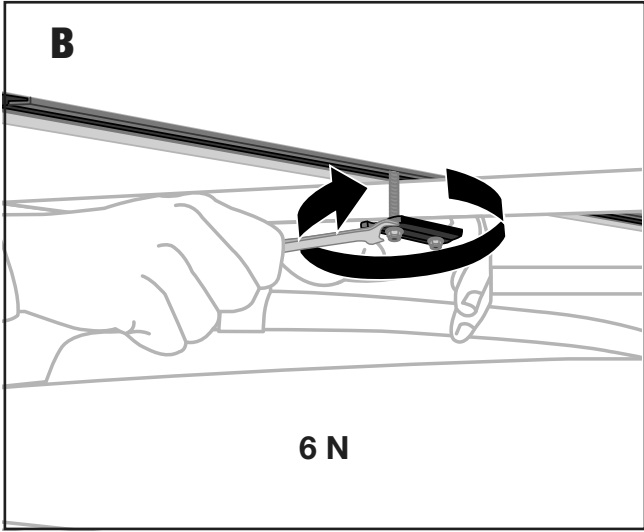
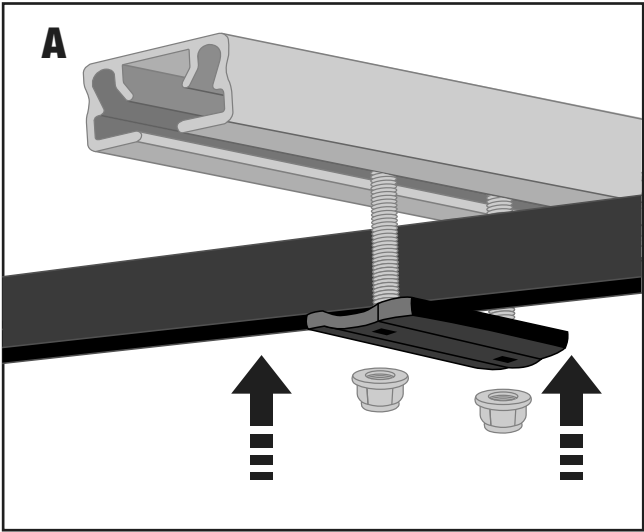

**7**

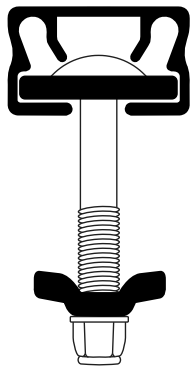
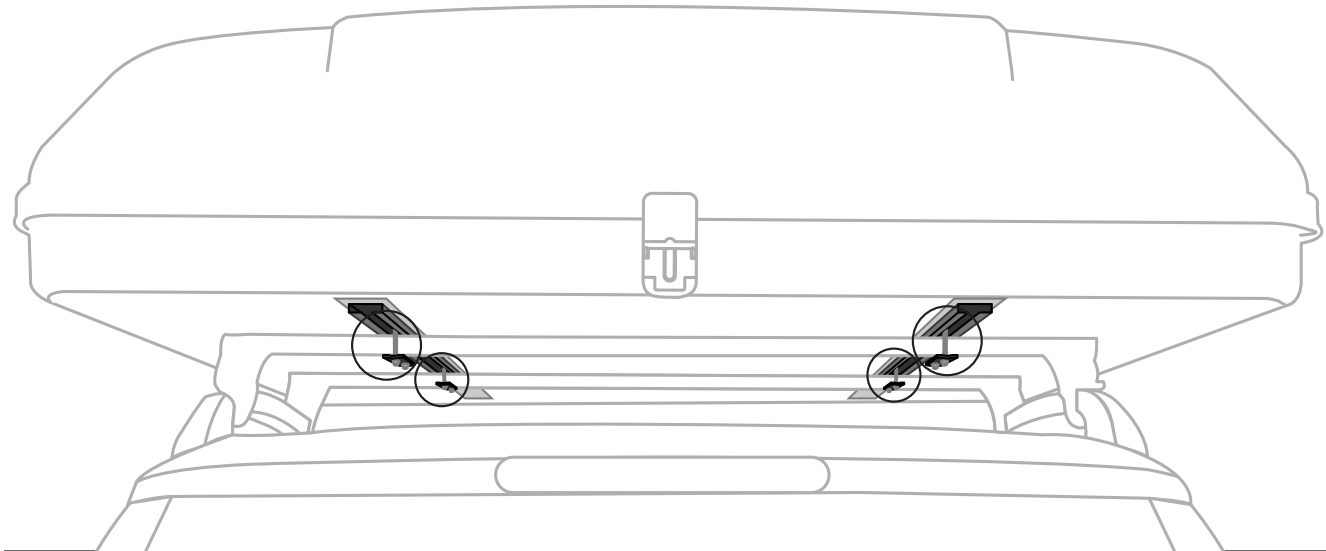

**X4**

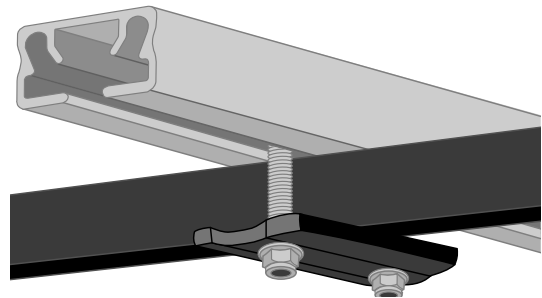

# OPENING

Apertura • Overture • Öffnung

8

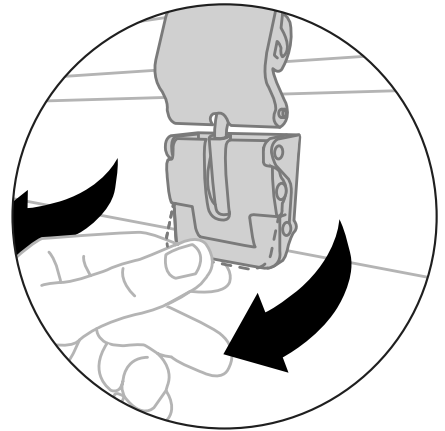
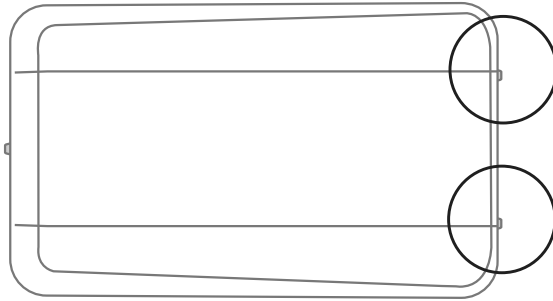

A

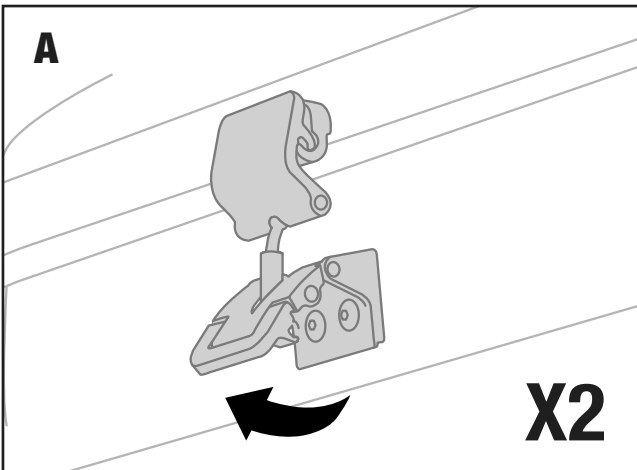

B

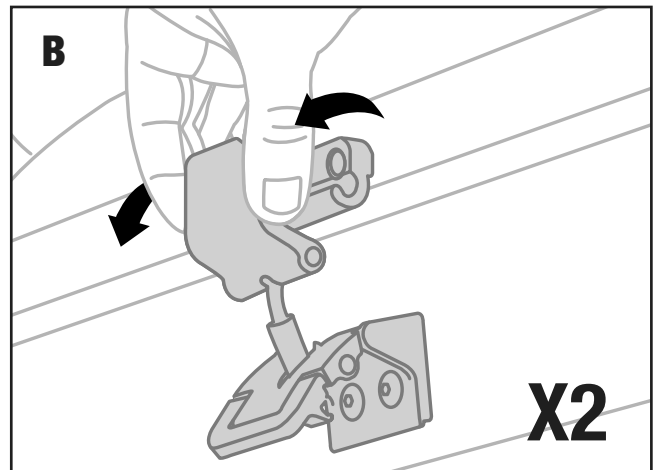

9

A

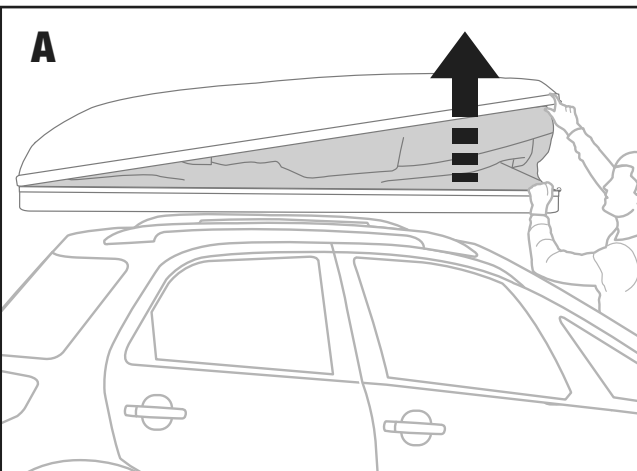

B

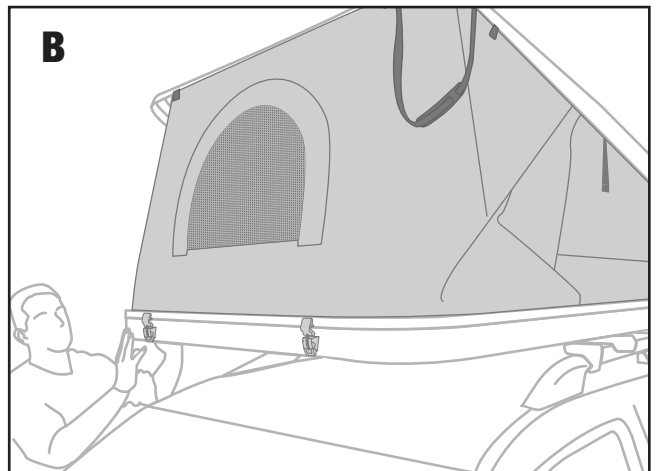

**10**

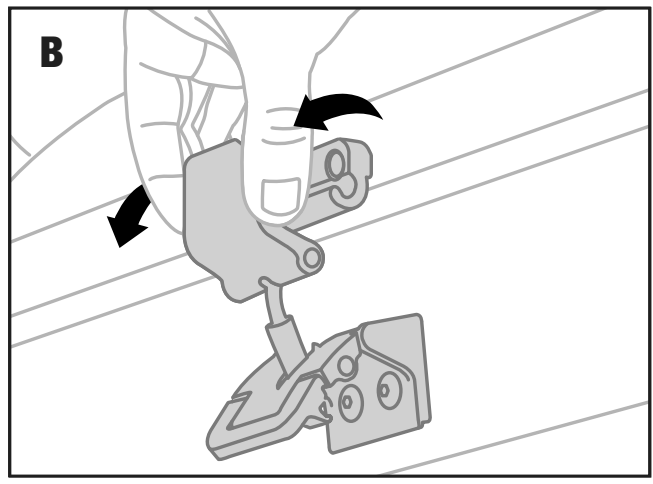
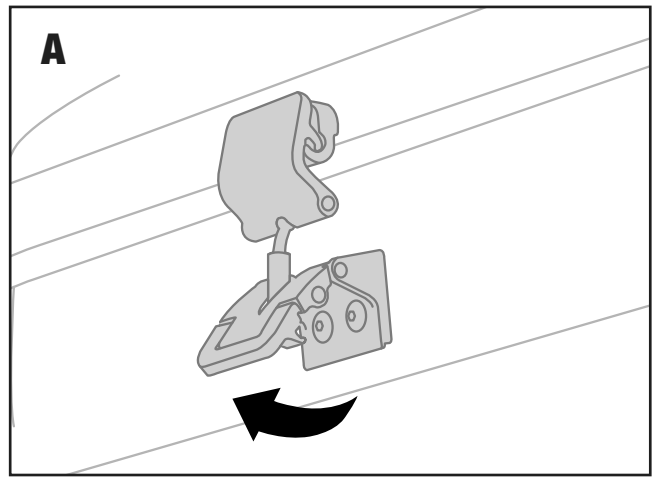
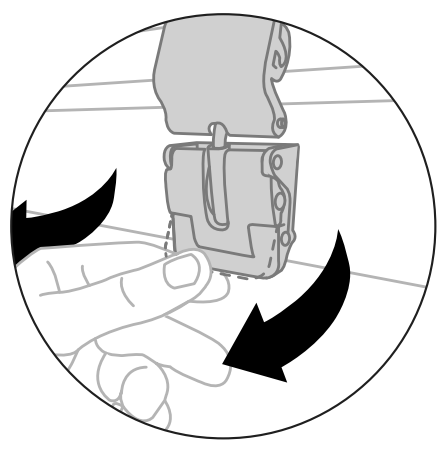
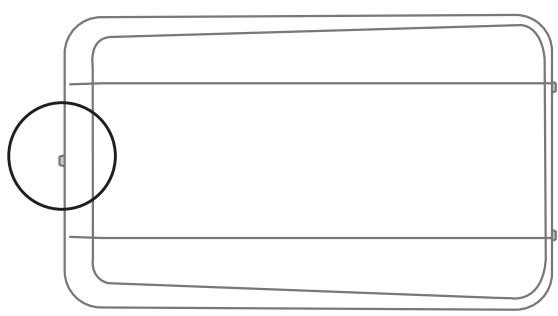

**11**

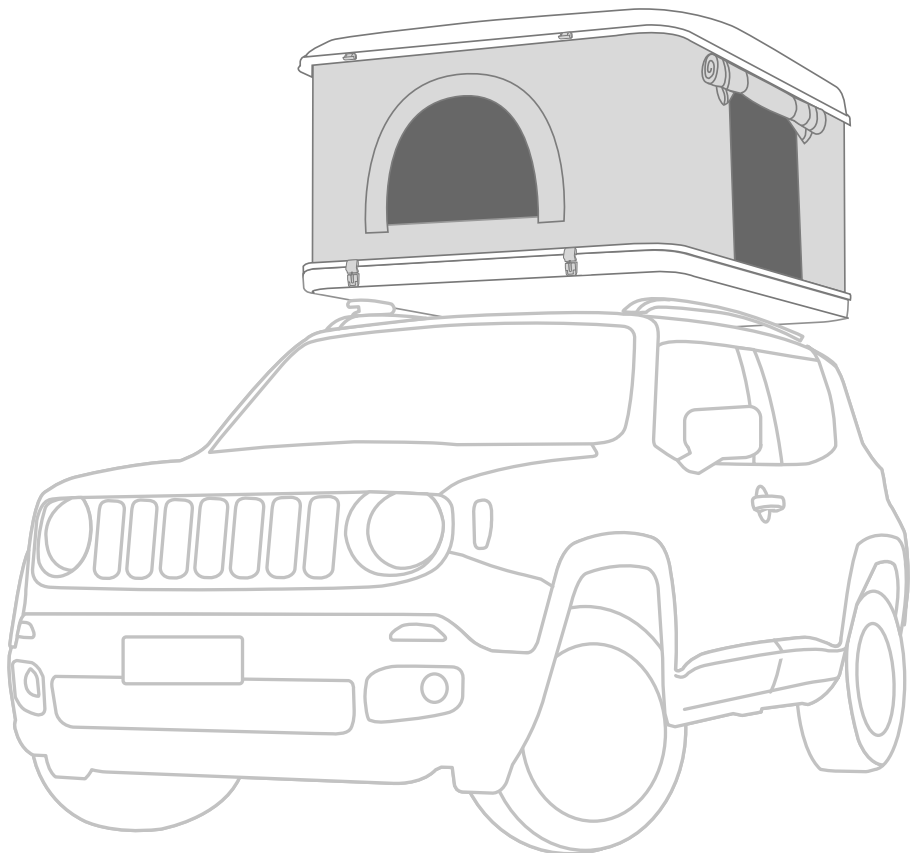

# WARNINGS

Avvertenze • Avertissement • Warnungen



12

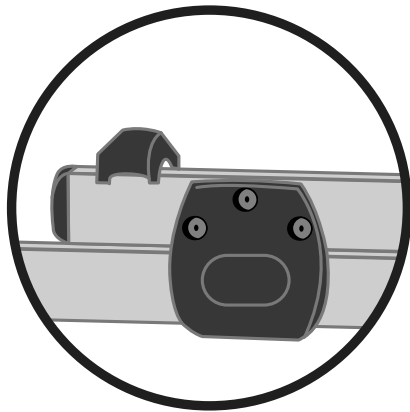
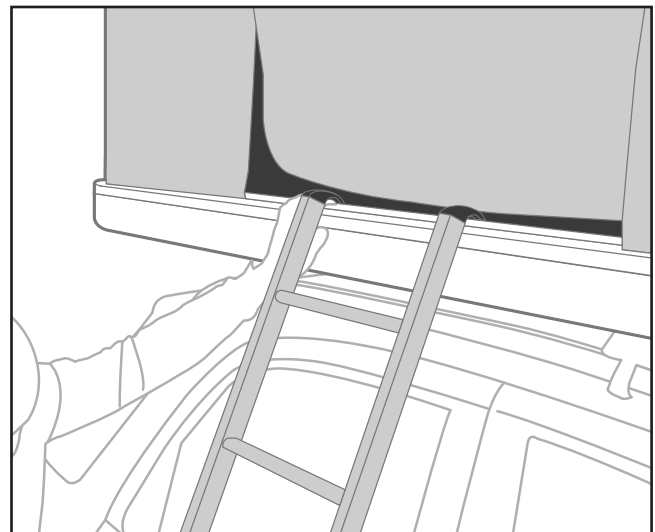
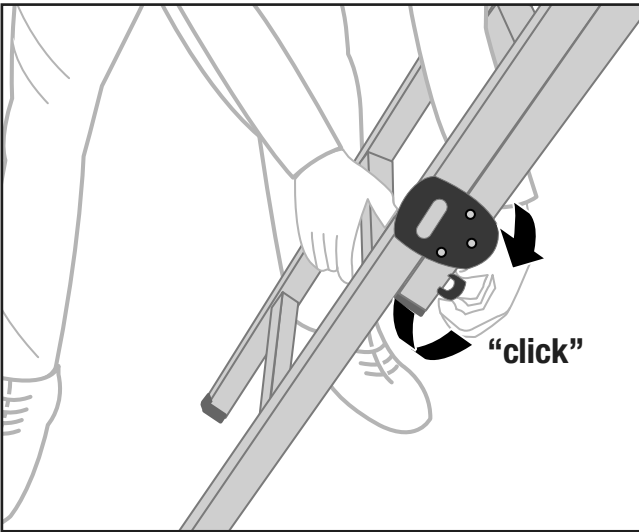
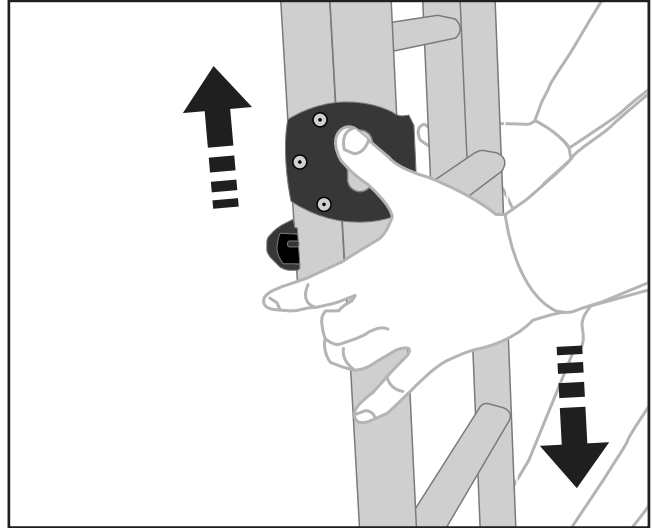
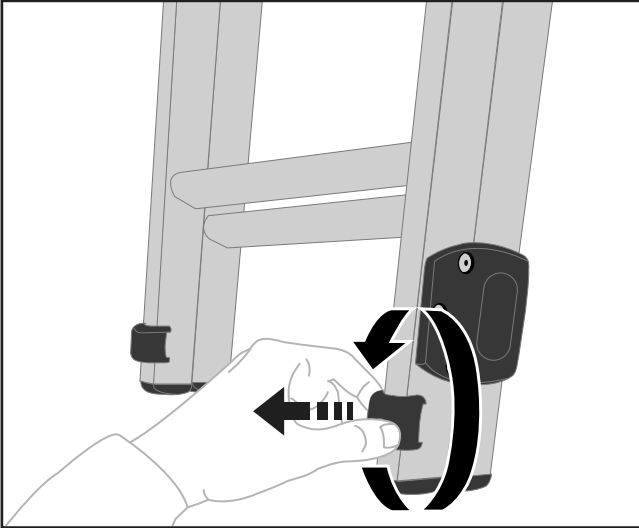

LOCK

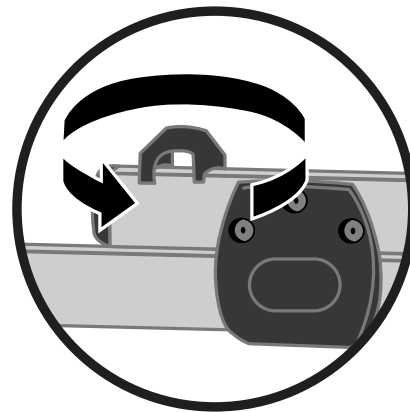

UNLOCK

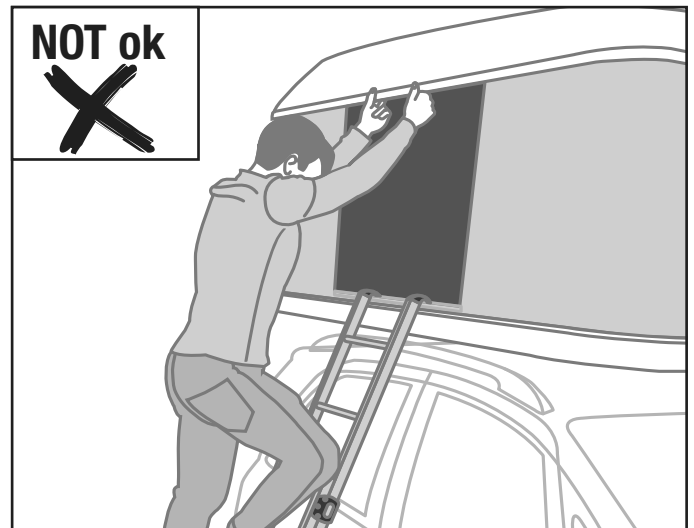
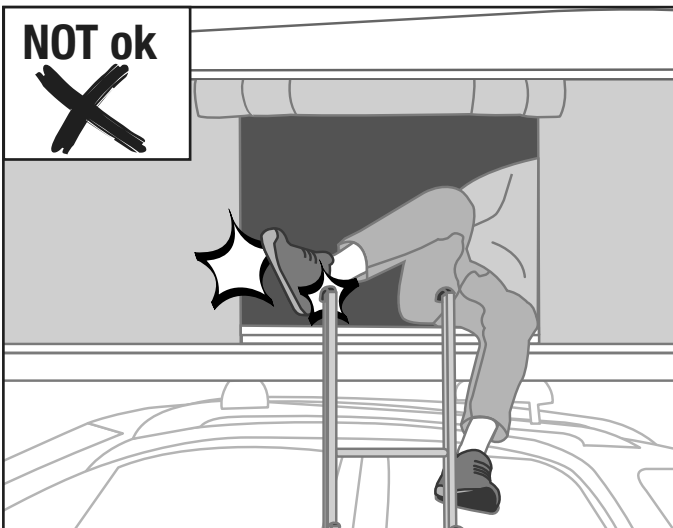
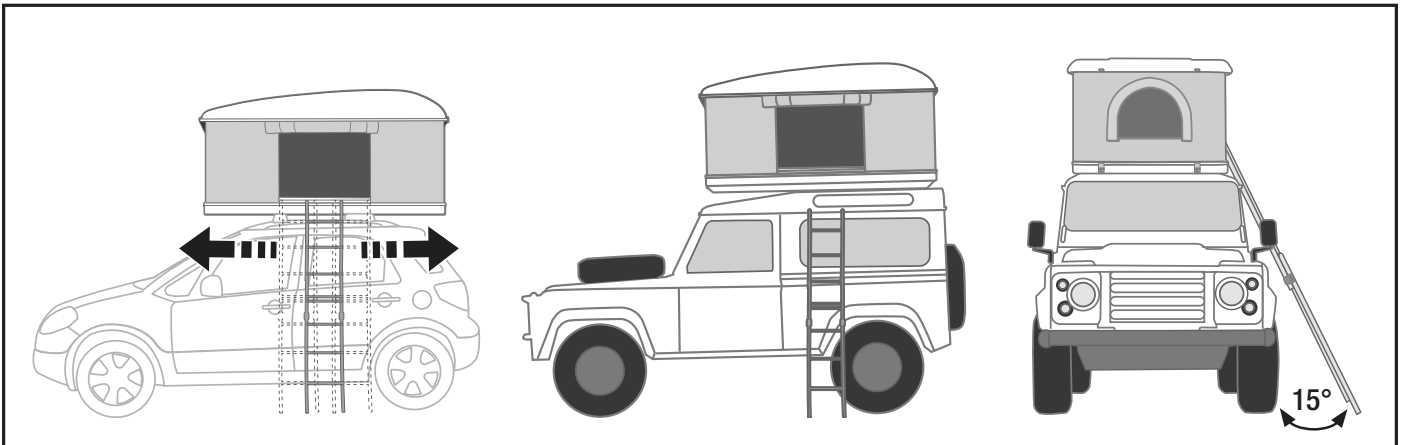
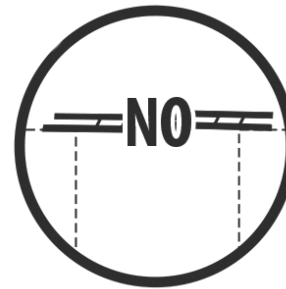
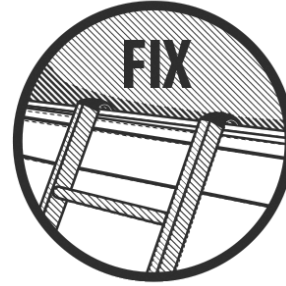

# CLOSING

Chiusura • Fermeture • Schließung

13

 **ATTENTION**

NOT ok  

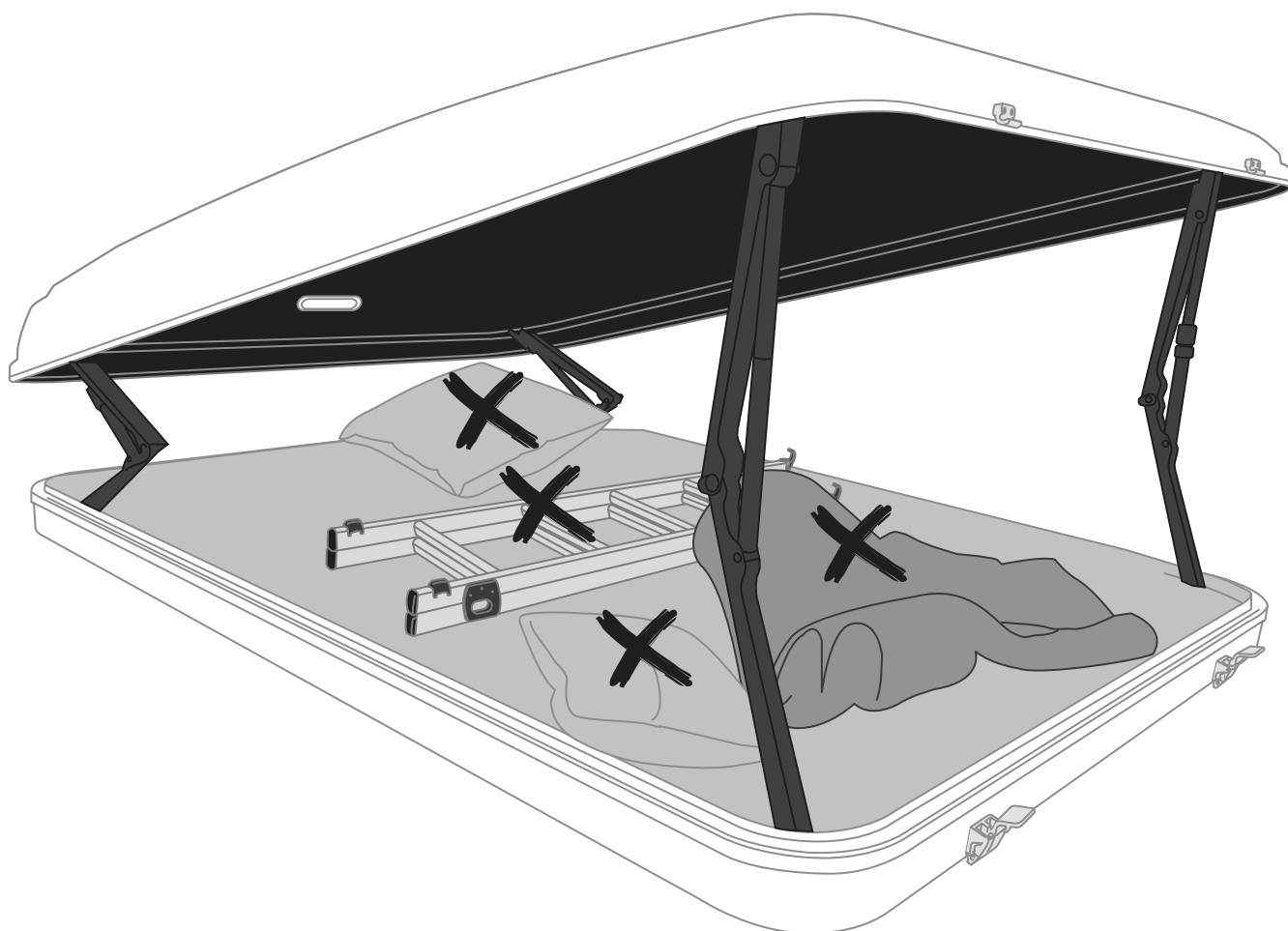

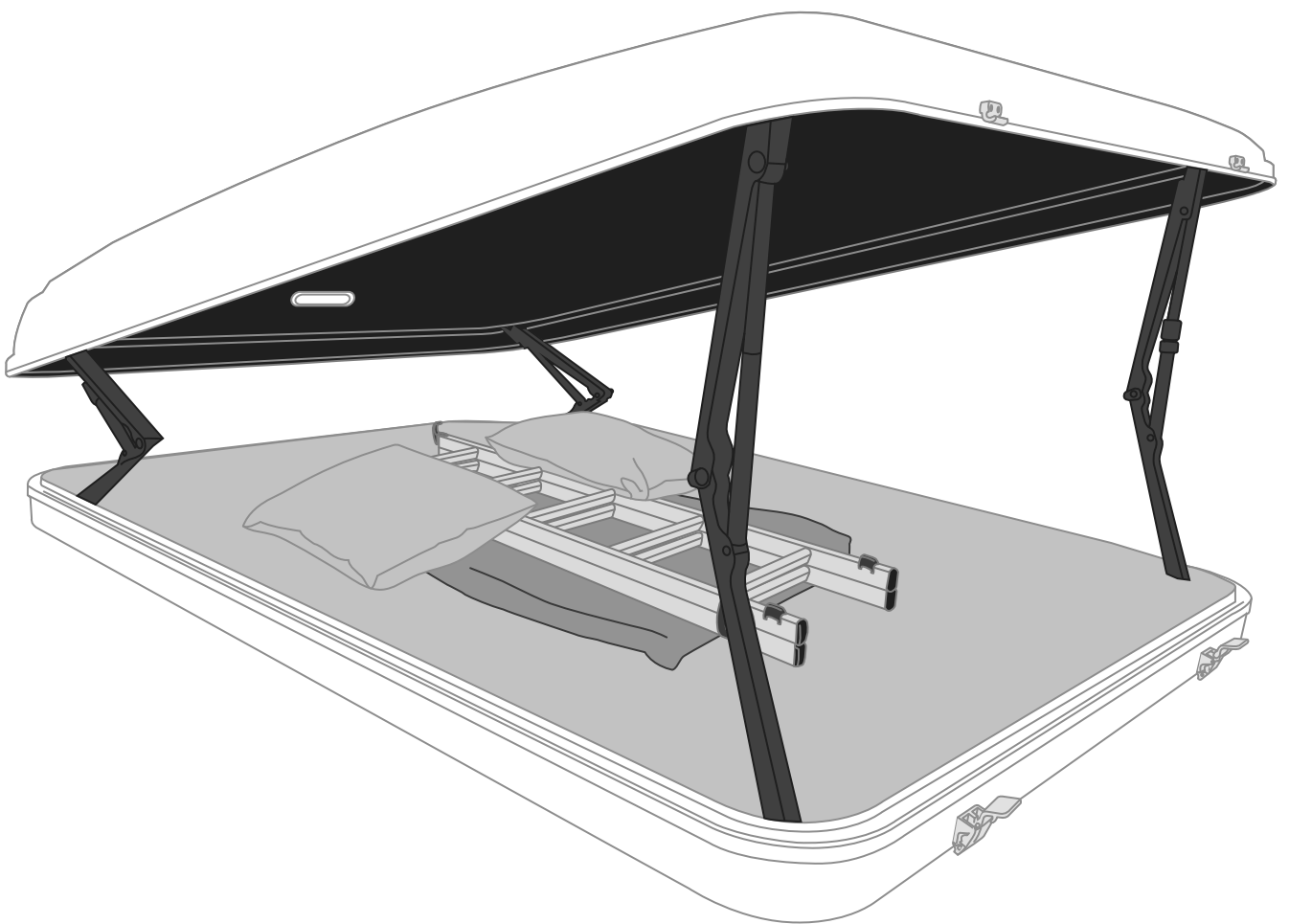

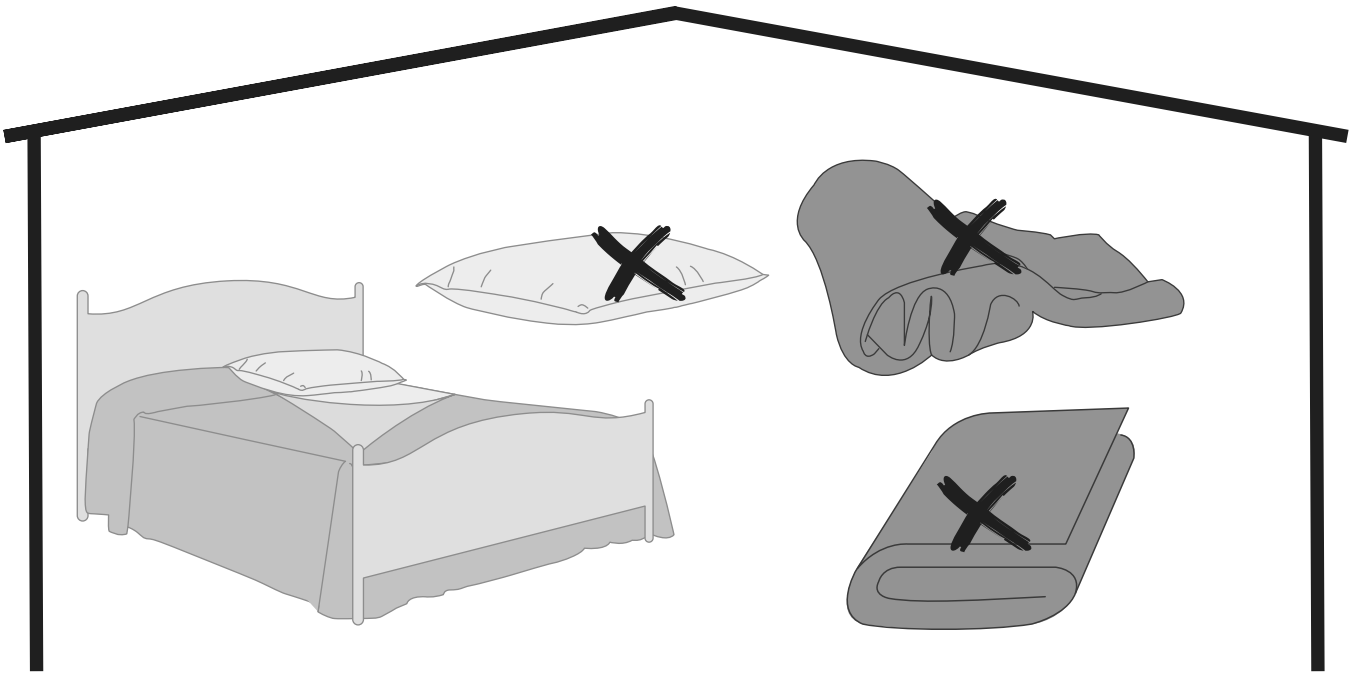
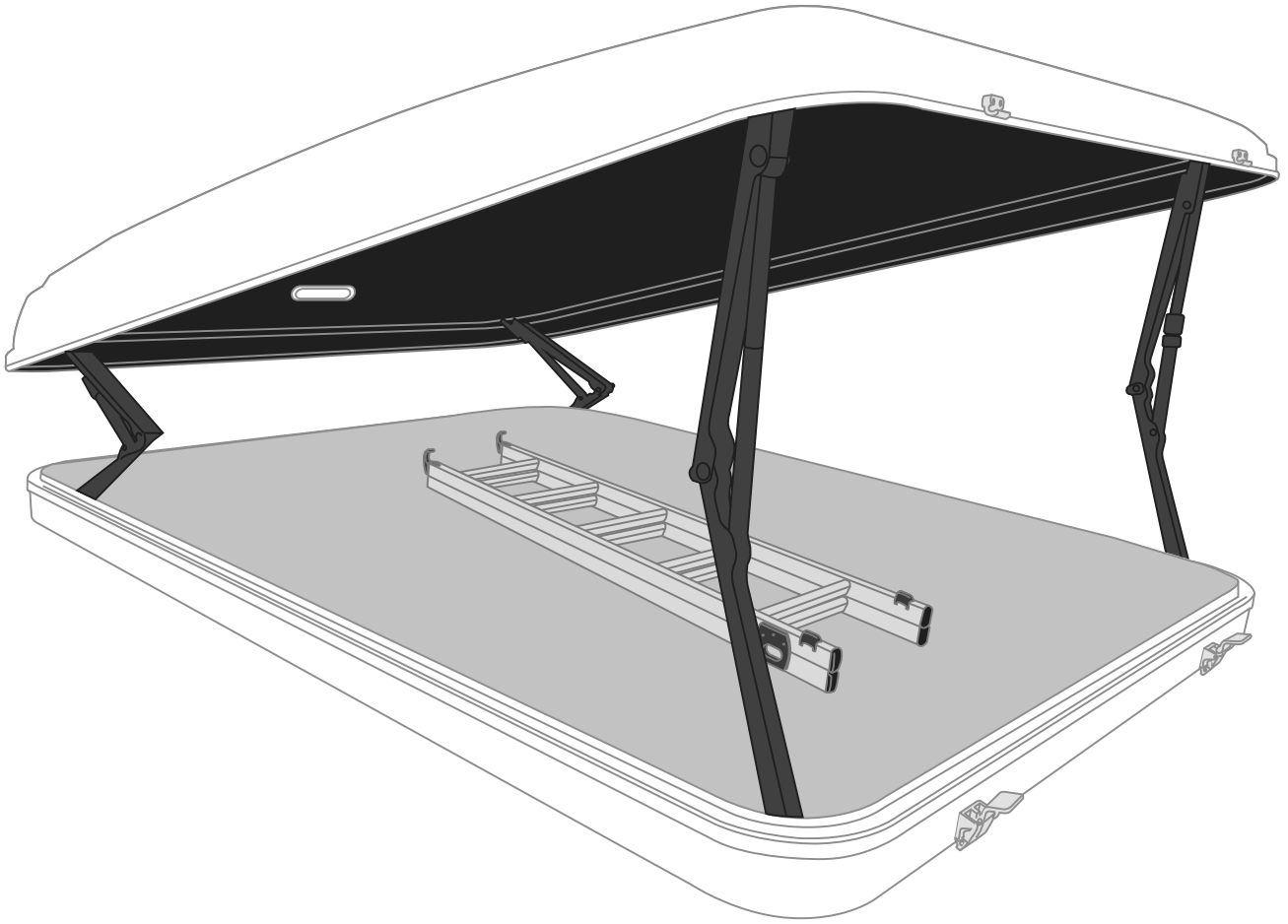
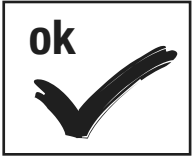



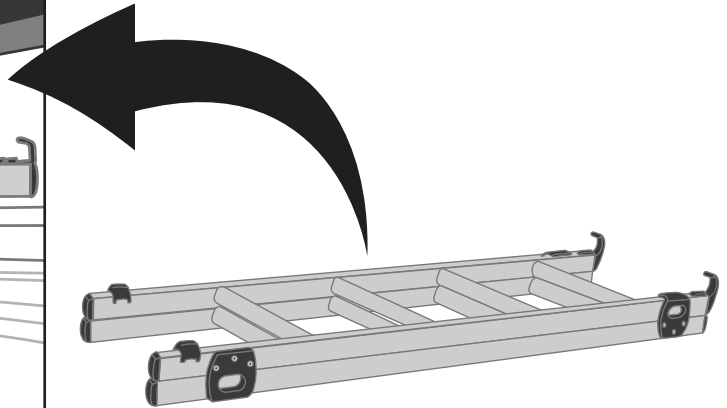
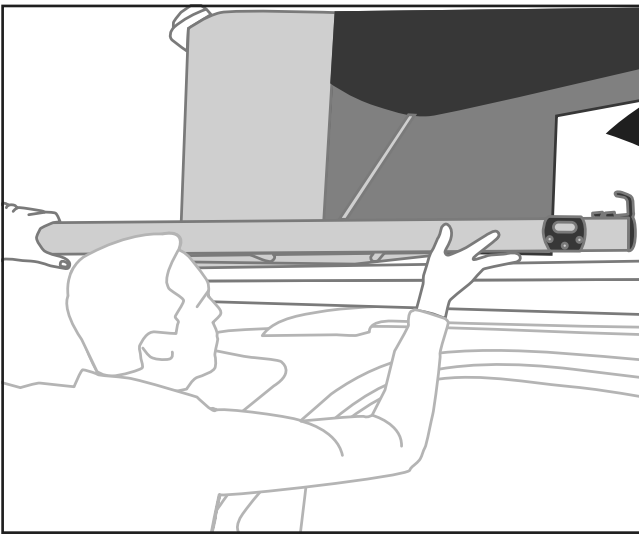

14



18-20 cm

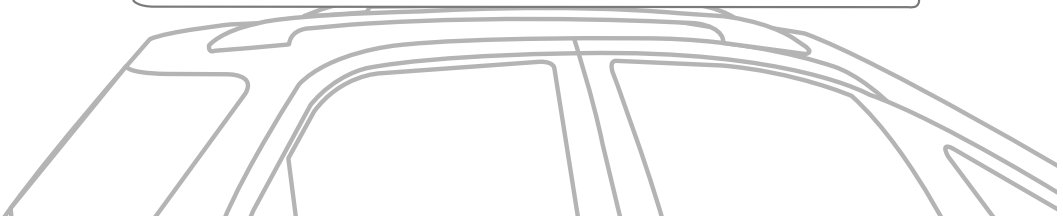
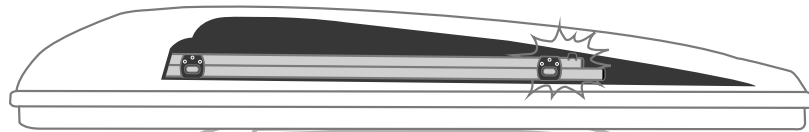
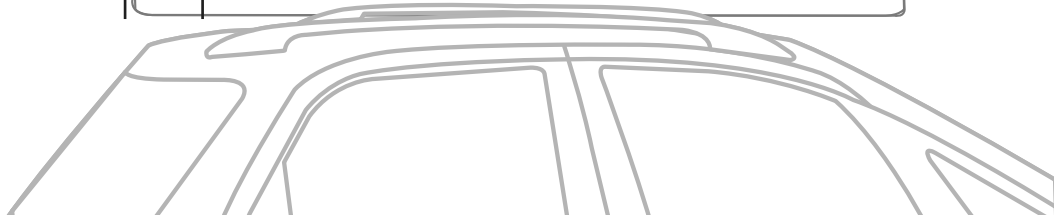
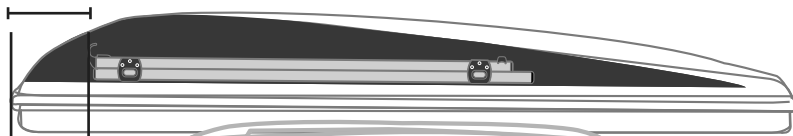

	AIRTOP SMALL	AIRTOP MEDIUM	AIRTOP LARGE
Standard ladder	✓ ok	✓ ok	✓ ok
Ladder 4X4	✗ NOT ok	✗ NOT ok	✗ NOT ok
Extra Long ladder	✗ NOT ok	✗ NOT ok	✗ NOT ok

**15**

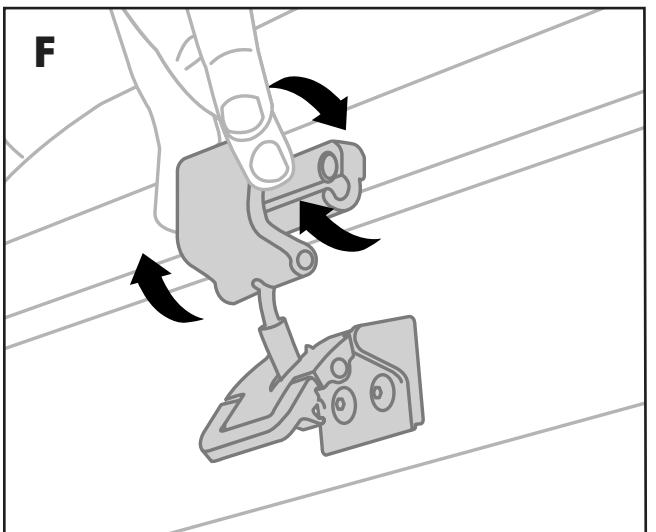
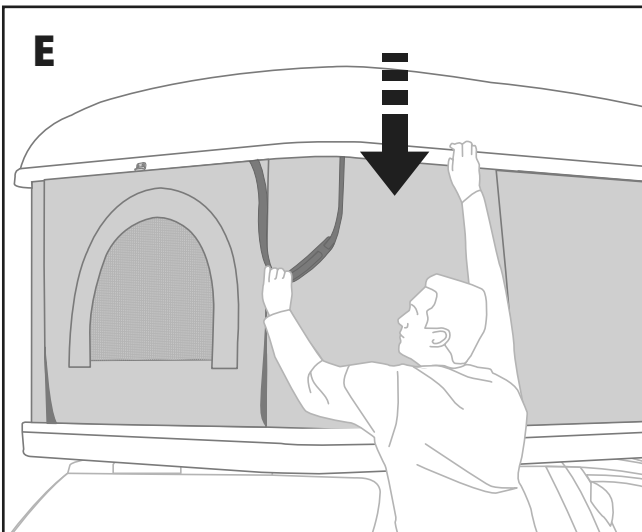
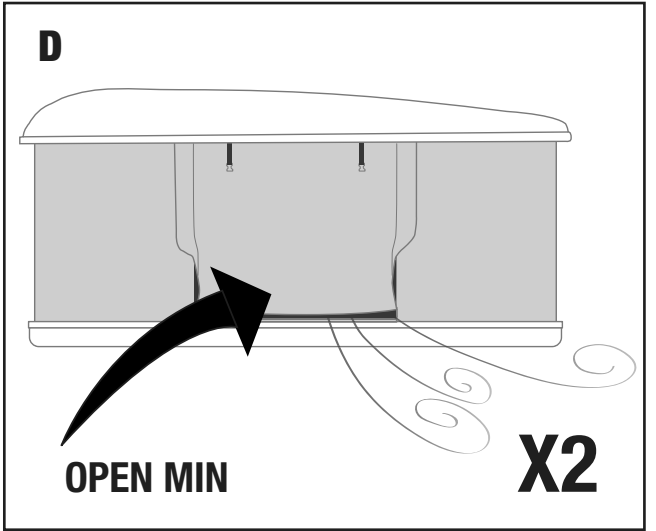
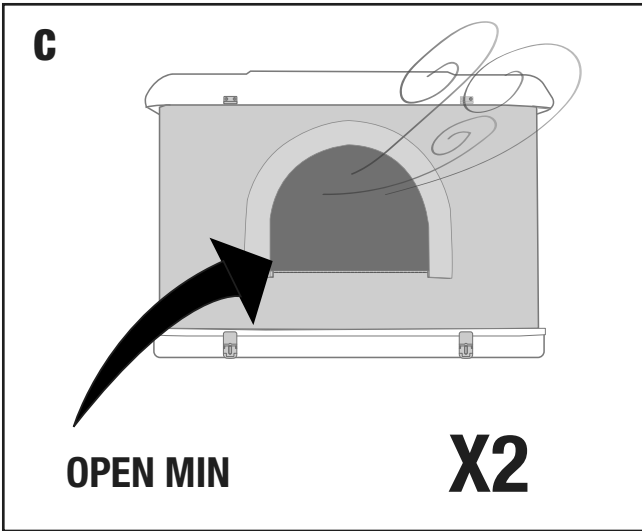
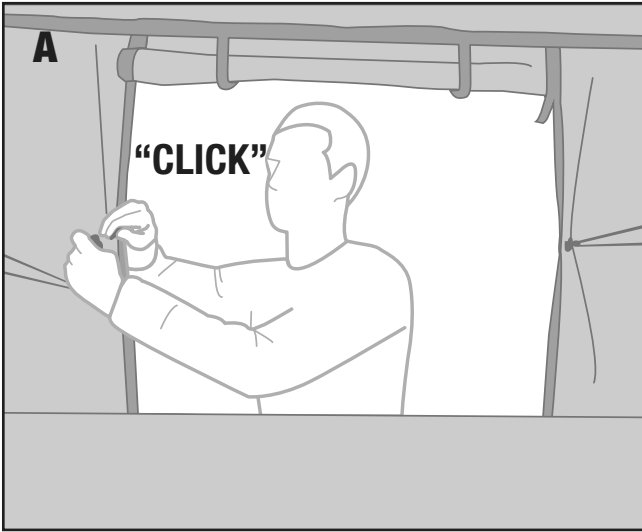

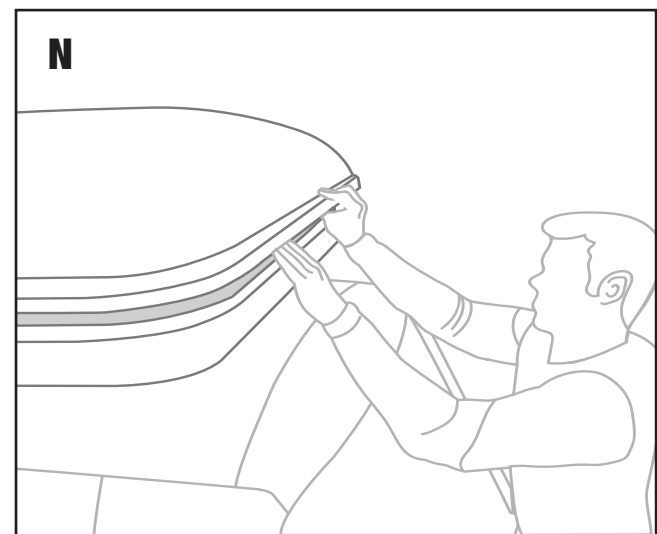
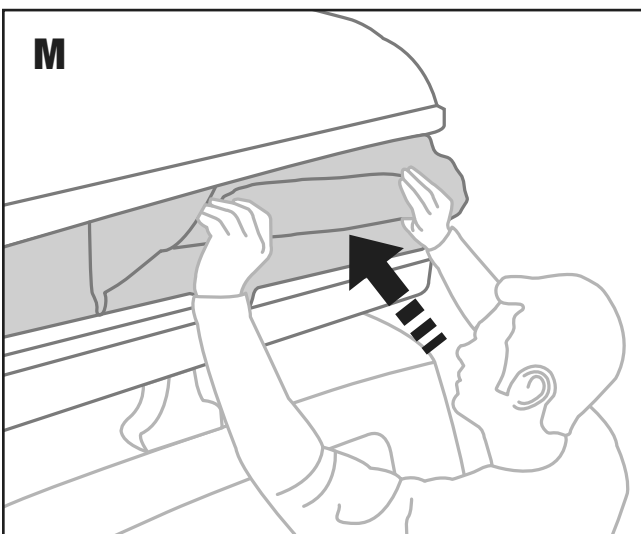
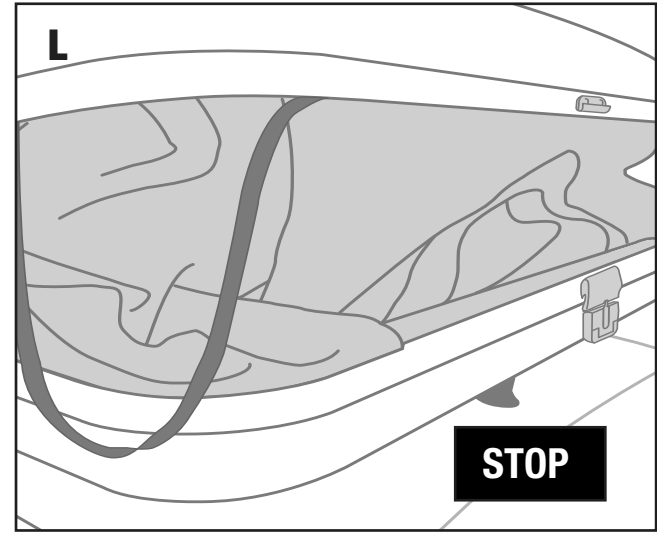
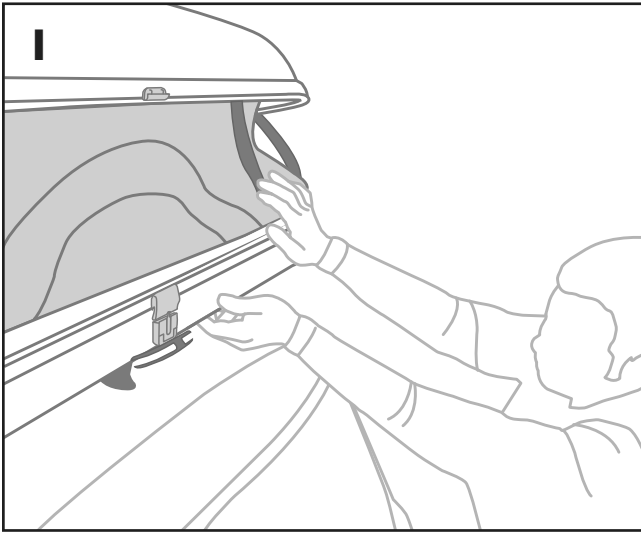
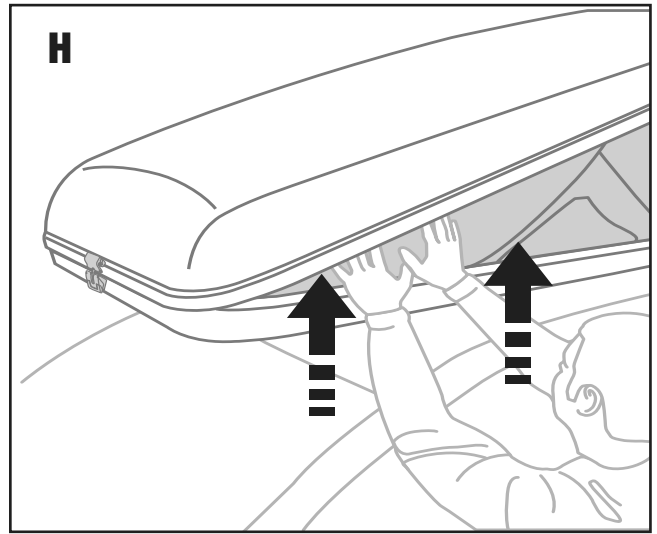
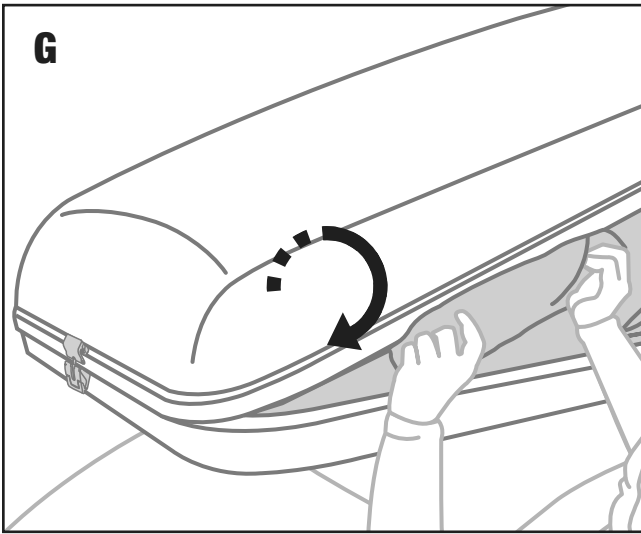

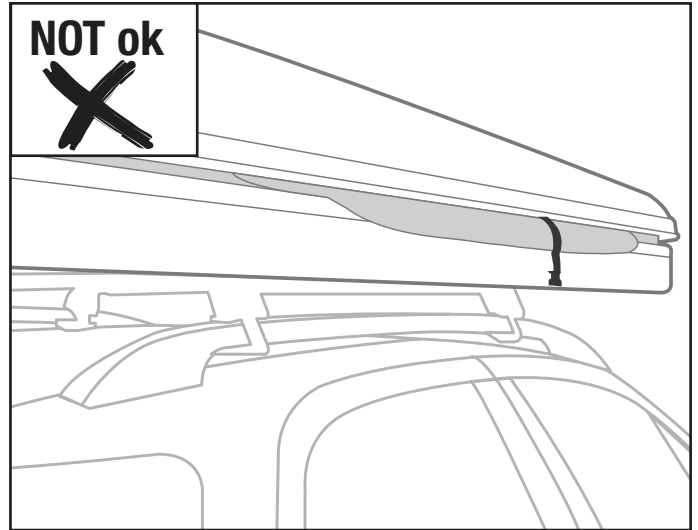
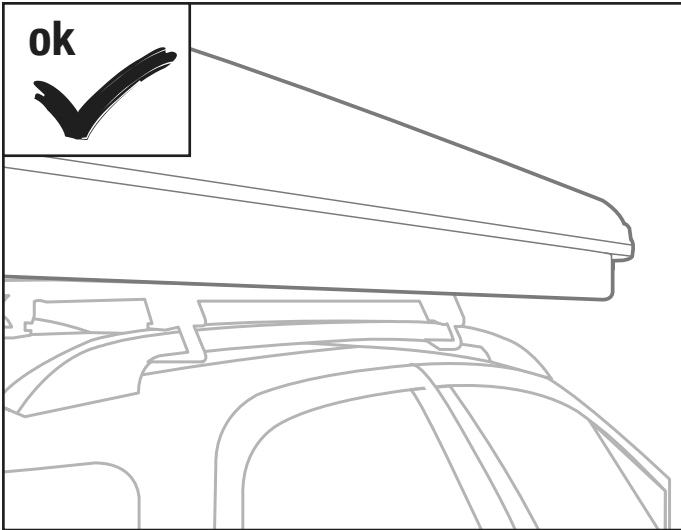

16

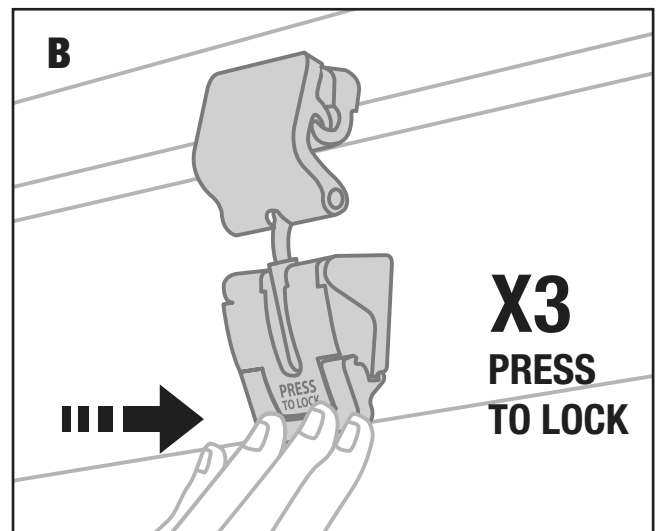
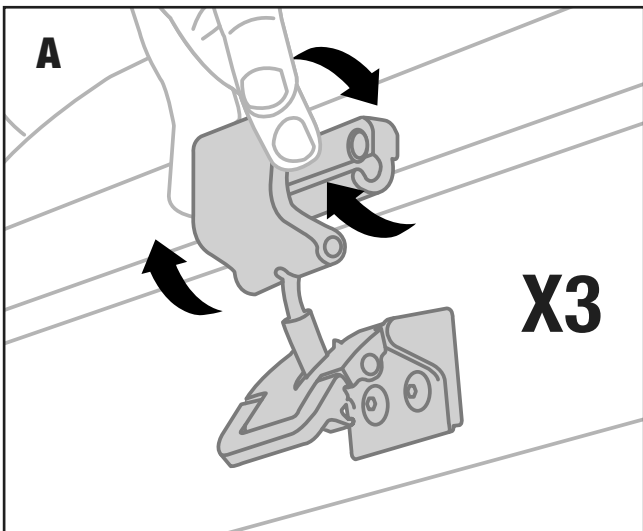
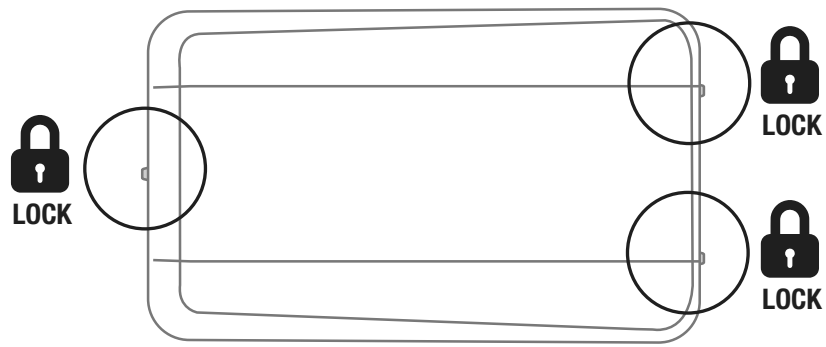

# ATTENTION

17

NOT ok  

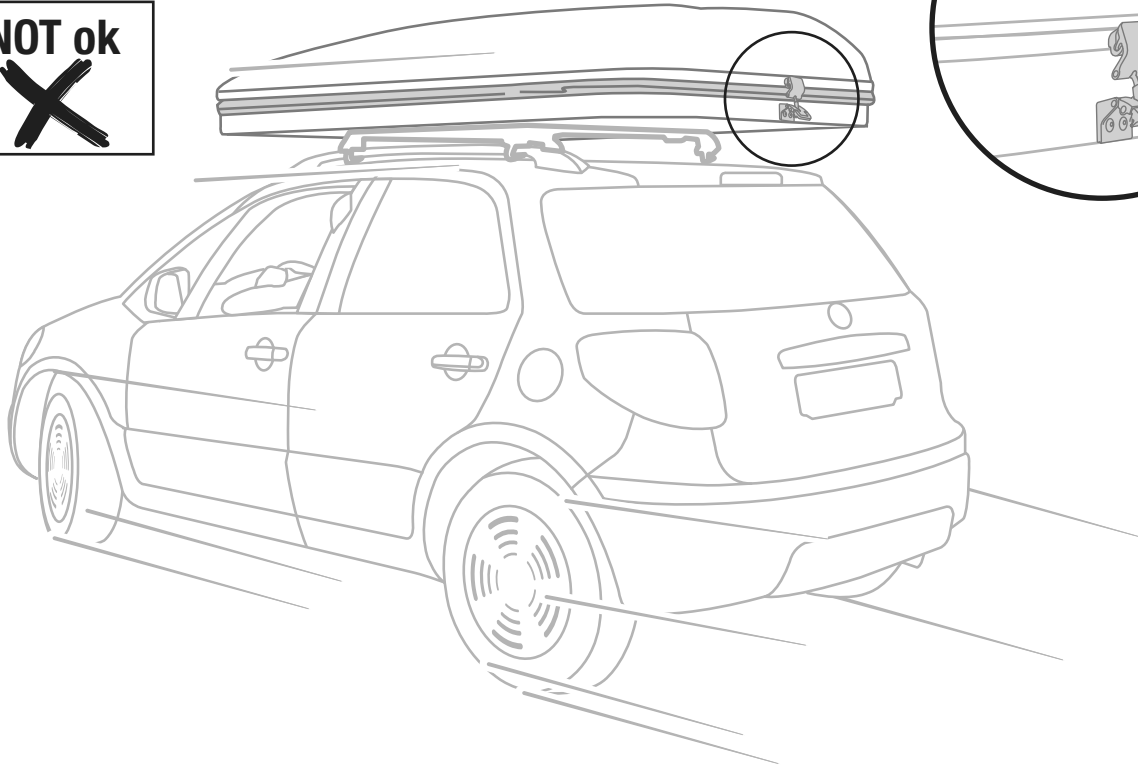
NOT ok  



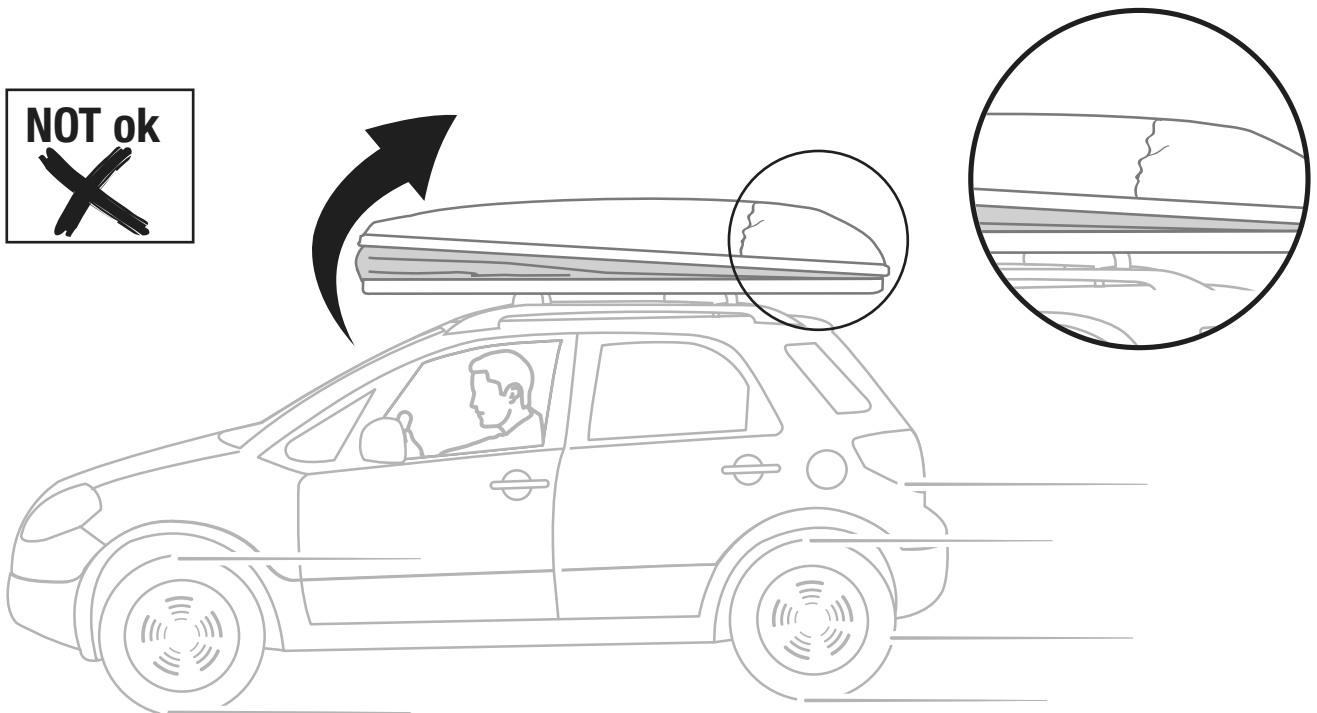

18

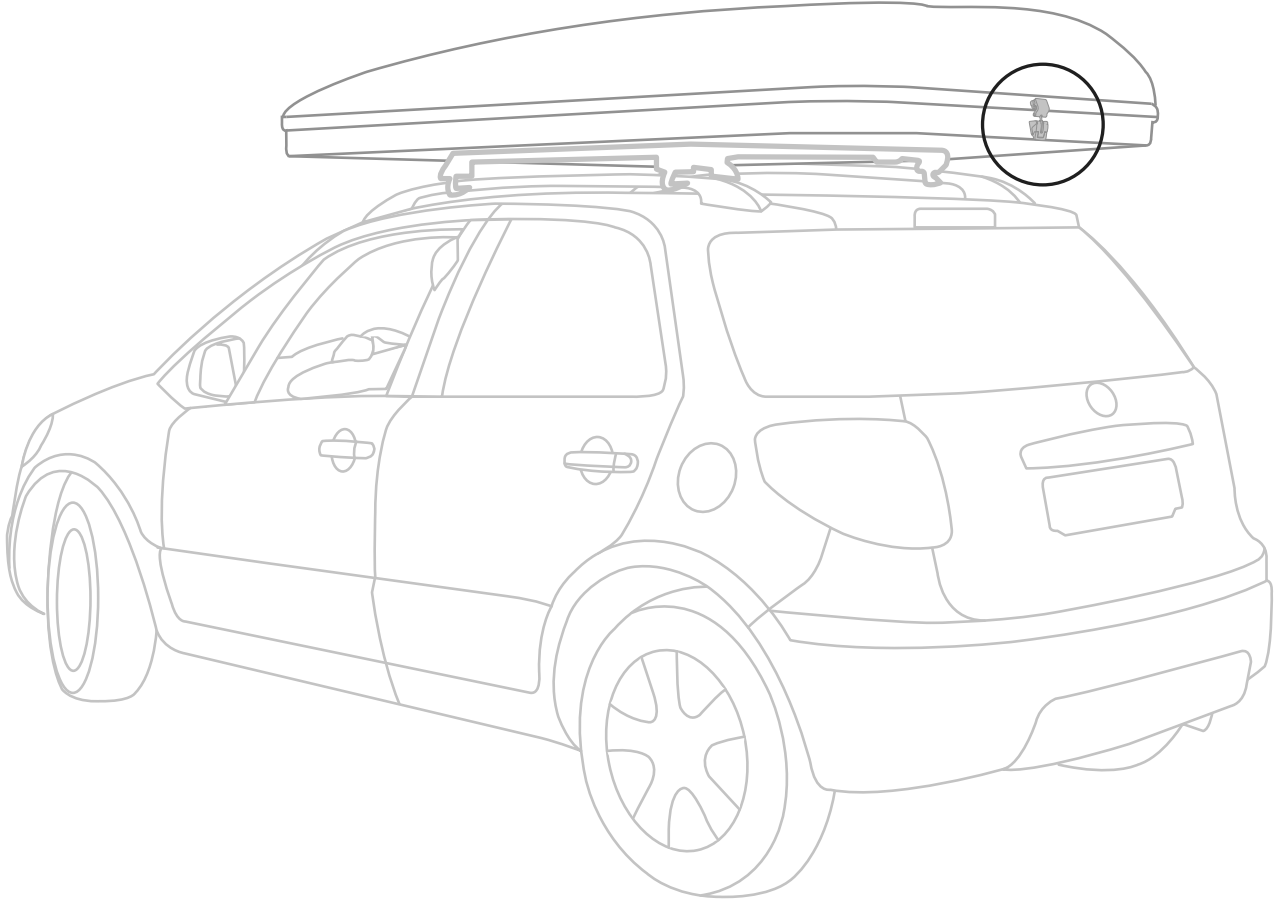
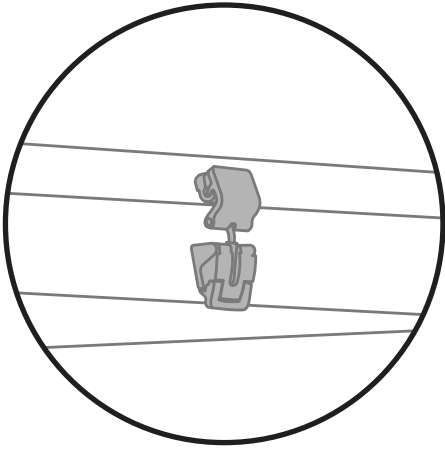

# LAMP

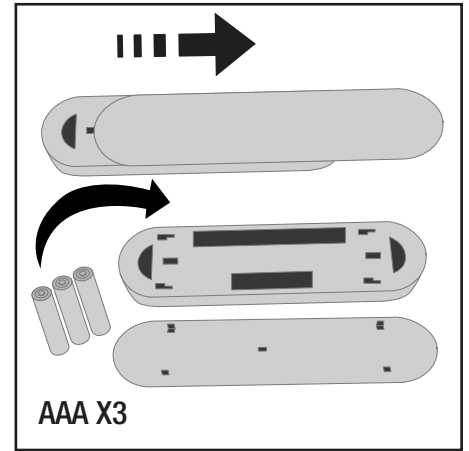
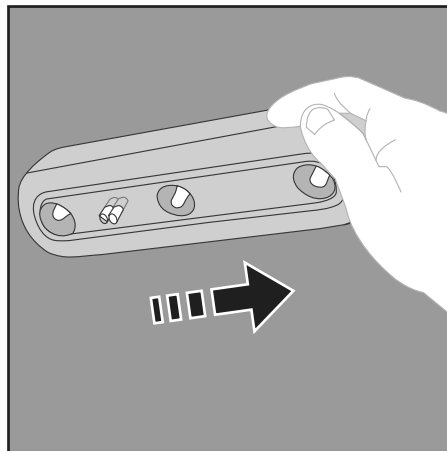
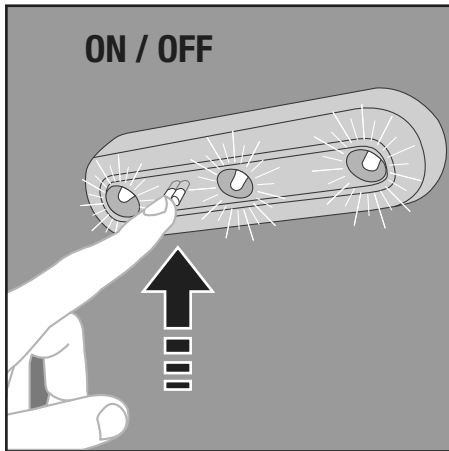
Lampada • Lampe • Lampe



# HANDLE WITH CARE

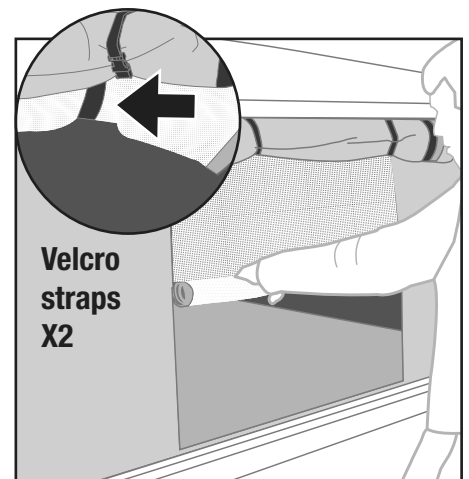
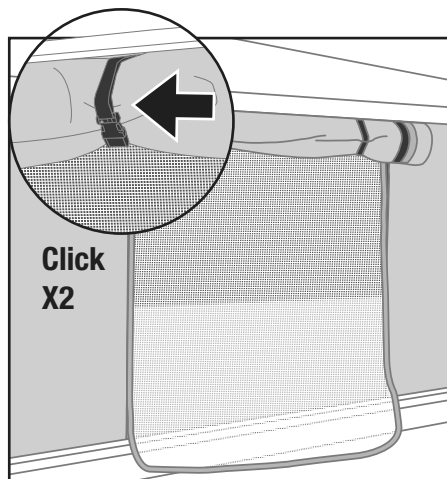
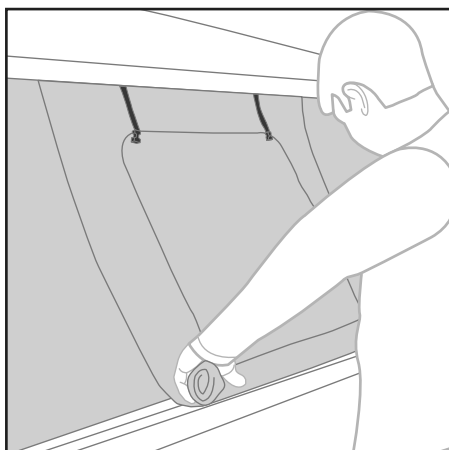
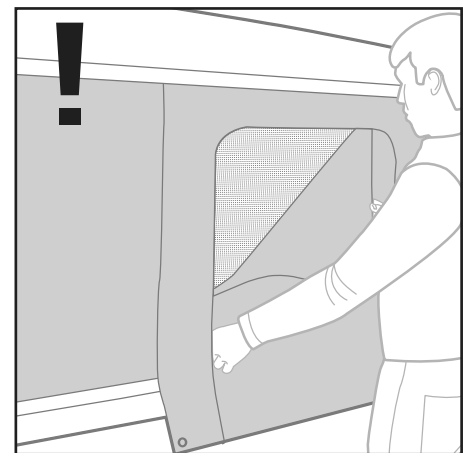
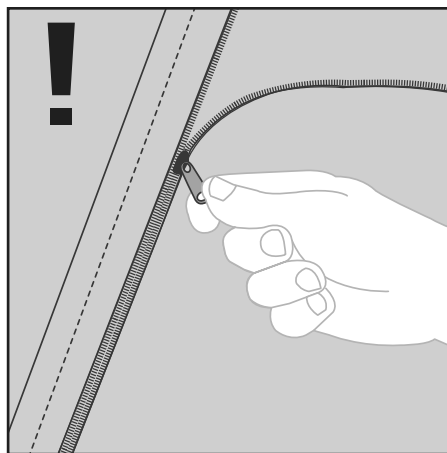
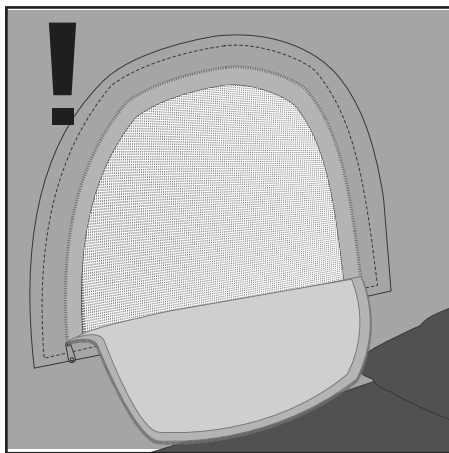

# WARNINGS

Avvertenze • Avertissement • Warnungen

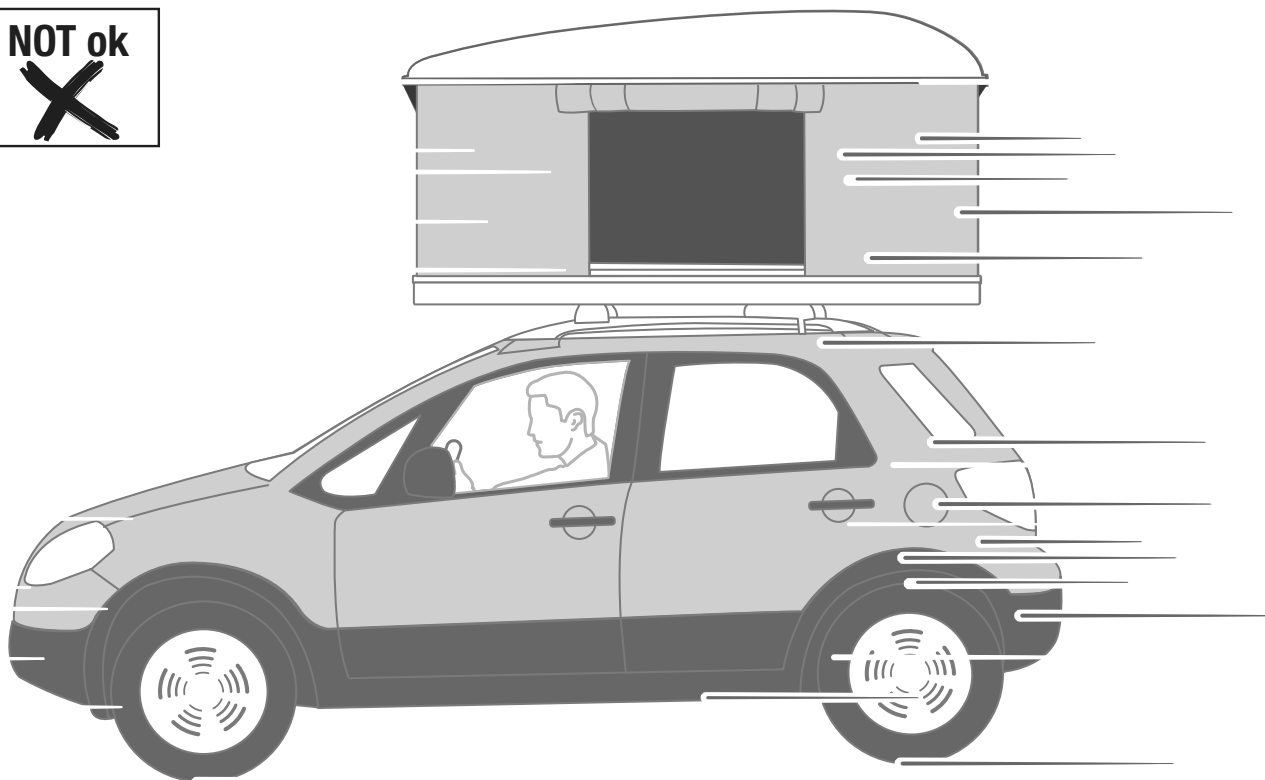
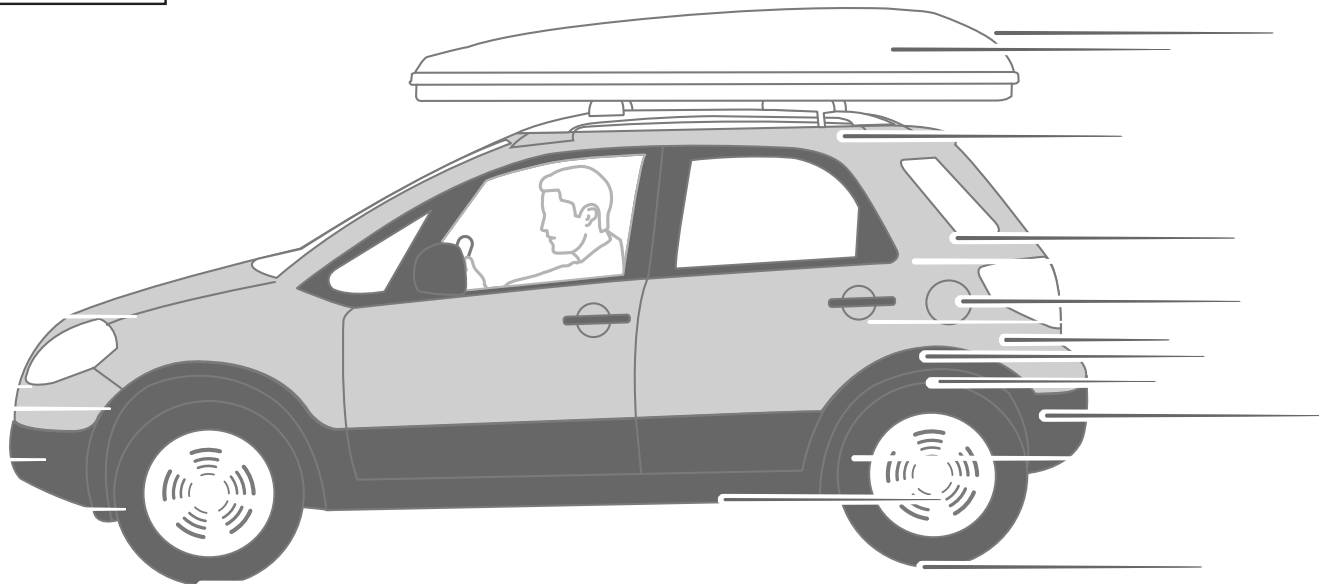



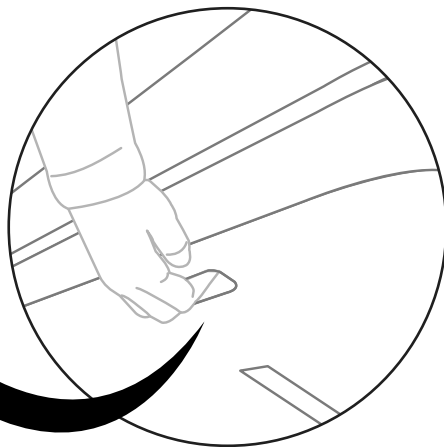
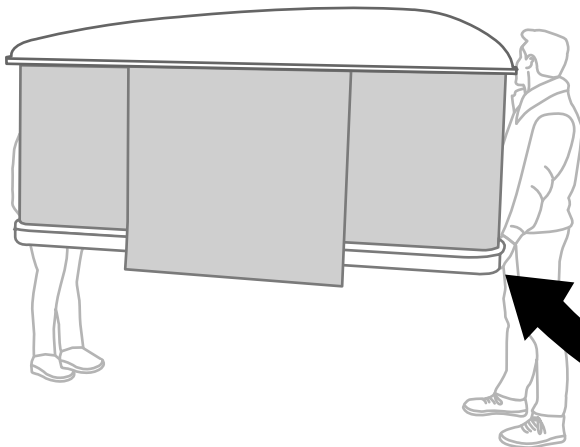
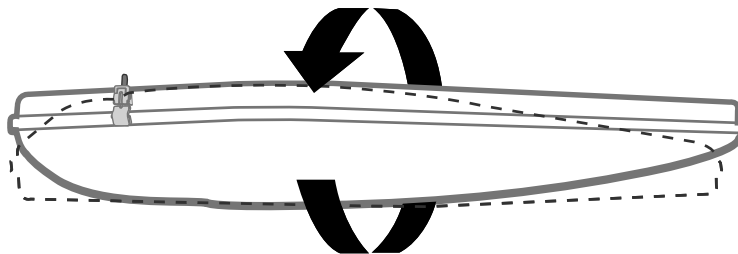
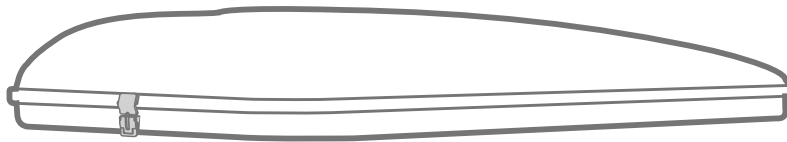
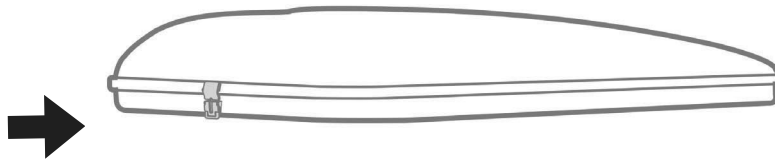
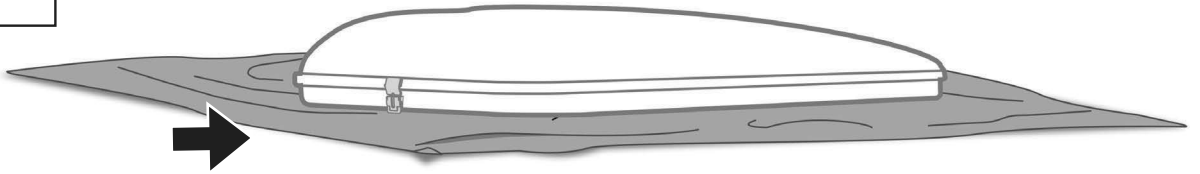

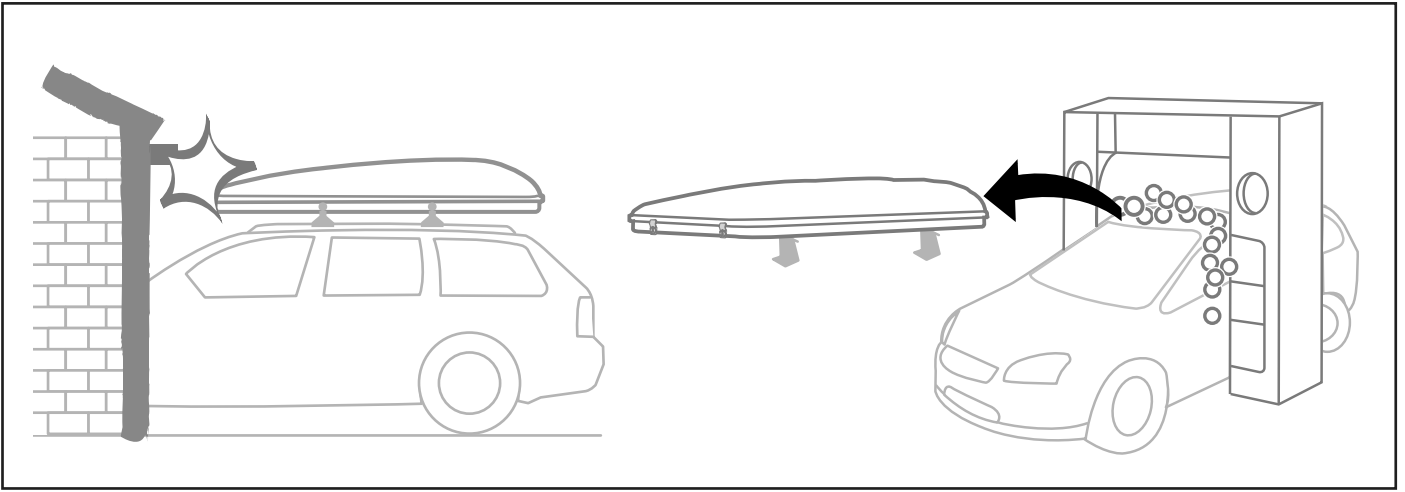







**AUTOHOME**<sup>®</sup> produced by  
Zifer Italia Srl  
Viale Risorgimento, 23  
46017 Rivarolo Mantovano  
(Mantova) Italy  
Tel. +39 0376 99590  
+39 0376 958164  
Fax +39 0376 958088

**AUTOHOME-OFFICIAL.COM**  
info@autohome.it

 MADE IN ITALY

 Autohome Official-Page

 autohome\_official



PRODUCT QUALITY CERTIFICATION